



MI TYPE

PRODUCT IDENTIFICATION

MI	-	160808	-	R10	K
1	2	3	4		

1. PRODUCT SYMBOLE
2. DIMENSION
3. INDUCTANCE
4. TOLERANCE (J=5% , K=10% , M=20%)

SHAPES, DIMENSIONS & RECOMMENDED PATTERN

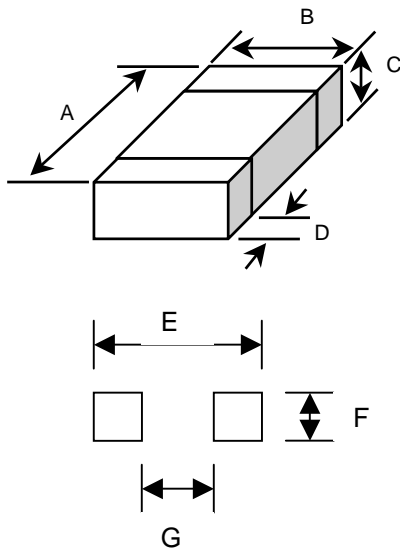

Dimension in mm (inch)

PART NO.	DIMENSIONS				RECOMMENDED PATTERN		
	A	B	C	D	E	F	G
MI-160808 (0603)	1.6 ± 0.15 (0.063±0.006)	0.8 ± 0.15 (0.031±0.006)	0.8 ± 0.15 (0.031±0.006)	0.3 ± 0.20 (0.012±0.008)	2.1 (0.083)	0.7 (0.028)	0.7 (0.028)
MI-201209 (0805)	2.0 ± 0.20 (0.079±0.008)	1.2 ± 0.20 (0.047±0.008)	0.9 ± 0.20 (0.035±0.008)	0.5 ± 0.30 (0.020±0.012)	2.6 (0.102)	1.0 (0.039)	1.0 (0.039)
MI-201212 (0805)	2.0 ± 0.20 (0.079±0.008)	1.2 ± 0.20 (0.047±0.008)	1.2 ± 0.20 (0.035±0.008)	0.5 ± 0.30 (0.020±0.012)	2.6 (0.102)	1.0 (0.039)	1.0 (0.039)
MI-321611 (1206)	3.2 ± 0.20 (0.126±0.008)	1.6 ± 0.20 (0.063±0.008)	1.1 ± 0.20 (0.043±0.008)	0.5 ± 0.30 (0.020±0.012)	4.4 (0.173)	1.4 (0.055)	2.2 (0.087)



Part Number	Inductance (μ H)	Tolerance	Q Min.	L, Q Test Frequency (MHz)	SRF (MHz) Min.	DC Resistance (Ω) Max.	Rated Current (mA) Max.
MI-160808-47N	0.047	M	10	50	260	0.15	50
MI-160808-56N	0.056	M	10	50	255	0.25	50
MI-160808-68N	0.068	M	10	50	250	0.25	50
MI-160808-82N	0.082	M	10	50	245	0.25	50
MI-160808-R10	0.10	J, K	15	25	240	0.50	50
MI-160808-R12	0.12	J, K	15	25	205	0.50	50
MI-160808-R15	0.15	J, K	15	25	180	0.60	50
MI-160808-R18	0.18	J, K	15	25	165	0.60	50
MI-160808-R22	0.22	J, K	15	25	150	0.80	50
MI-160808-R27	0.27	J, K	15	25	136	0.80	50
MI-160808-R33	0.33	J, K	15	25	125	0.85	35
MI-160808-R39	0.39	J, K	15	25	110	1.00	35
MI-160808-R47	0.47	J, K	15	25	105	1.35	35
MI-160808-R56	0.56	J, K	15	25	95	1.55	35
MI-160808-R68	0.68	J, K	15	25	90	1.70	35
MI-160808-R82	0.82	J, K	15	25	85	2.10	35
MI-160808-1R0	1.00	J, K	35	10	75	0.60	25
MI-160808-1R2	1.20	J, K	35	10	65	0.80	25
MI-160808-1R5	1.50	J, K	35	10	60	0.80	25
MI-160808-1R8	1.80	J, K	35	10	55	0.95	25
MI-160808-2R2	2.20	J, K	35	10	50	1.15	15
MI-160808-2R7	2.70	J, K	35	10	45	1.35	15
MI-160808-3R3	3.30	J, K	35	10	40	1.55	15
MI-160808-3R9	3.90	J, K	35	10	35	1.70	15
MI-160808-4R7	4.70	J, K	35	10	33	2.10	15
MI-160808-5R6	5.60	J, K	35	4	22	1.55	5
MI-160808-6R8	6.80	J, K	35	4	20	1.70	5
MI-160808-8R2	8.20	J, K	35	4	18	2.10	5
MI-160808-100	10.00	J, K	30	2	17	1.85	3
MI-160808-120	12.00	J, K	30	2	15	2.10	3

(J=5%, K=10%, M=20%)



Part Number	Inductance (μ H)	Tolerance	Q Min.	L, Q Test Frequency (MHz)	SRF (MHz) Min.	DC Resistance (Ω) Max.	Rated Current (mA) Max.
MI-201209-47N	0.047	M	15	50	320	0.20	300
MI-201209-68N	0.068	M	15	50	280	0.20	300
MI-201209-82N	0.082	M	15	50	255	0.20	300
MI-201209-R10	0.10	J, K	20	25	235	0.30	250
MI-201209-R12	0.12	J, K	20	25	220	0.30	250
MI-201209-R15	0.15	J, K	20	25	200	0.40	250
MI-201209-R18	0.18	J, K	20	25	185	0.40	250
MI-201209-R22	0.22	J, K	20	25	170	0.50	250
MI-201209-R27	0.27	J, K	20	25	150	0.50	250
MI-201209-R33	0.33	J, K	20	25	145	0.55	250
MI-201209-R39	0.39	J, K	25	25	135	0.65	200
MI-201209-R47	0.47	J, K	25	25	125	0.65	200
MI-201209-R56	0.56	J, K	25	25	115	0.75	150
MI-201209-R68	0.68	J, K	25	25	105	0.80	150
MI-201209-R82	0.82	J, K	25	25	100	1.00	150
MI-201209-1R0	1.00	J, K	45	10	75	0.40	50
MI-201209-1R2	1.20	J, K	45	10	65	0.50	50
MI-201209-1R5	1.50	J, K	45	10	60	0.50	50
MI-201209-1R8	1.80	J, K	45	10	55	0.60	50
MI-201209-2R2	2.20	J, K	45	10	50	0.65	30
MI-201212-2R7	2.70	J, K	45	10	45	0.75	30
MI-201212-3R3	3.30	J, K	45	10	41	0.80	30
MI-201212-3R9	3.90	J, K	45	10	38	0.90	30
MI-201212-4R7	4.70	J, K	45	10	35	1.00	30
MI-201212-5R6	5.60	J, K	50	4	55	0.90	15
MI-201212-6R8	6.80	J, K	50	4	53	1.00	15
MI-201212-8R2	8.20	J, K	50	4	45	1.10	25
MI-201212-100	10.00	J, K	50	2	24	1.15	15
MI-201212-120	12.00	J, K	50	2	22	1.15	15

(J=5%, K=10%, M=20%)



Part Number	Inductance (μH)	Tolerance	Q Min.	L, Q Test Frequency (MHz)	SRF (MHz) Min.	DC Resistance (Ω) Max.	Rated Current (mA) Max.
MI-321611-47N	0.047	M	20	50	320	0.15	300
MI-321611-68N	0.068	M	20	50	280	0.20	300
MI-321611-R10	0.10	J, K	20	25	235	0.25	250
MI-321611-R12	0.12	J, K	20	25	220	0.30	250
MI-321611-R15	0.15	J, K	20	25	200	0.30	250
MI-321611-R18	0.18	J, K	20	25	185	0.40	250
MI-321611-R22	0.22	J, K	20	25	170	0.40	250
MI-321611-R27	0.27	J, K	20	25	150	0.50	250
MI-321611-R33	0.33	J, K	20	25	145	0.60	250
MI-321611-R39	0.39	J, K	25	25	135	0.50	200
MI-321611-R47	0.47	J, K	25	25	125	0.60	200
MI-321611-R56	0.56	J, K	25	25	115	0.70	150
MI-321611-R68	0.68	J, K	25	25	105	0.80	150
MI-321611-R82	0.82	J, K	25	25	100	0.90	150
MI-321611-1R0	1.00	J, K	45	10	75	0.40	100
MI-321611-1R2	1.20	J, K	45	10	65	0.50	100
MI-321611-1R5	1.50	J, K	45	10	60	0.50	50
MI-321611-1R8	1.80	J, K	45	10	55	0.50	50
MI-321611-2R2	2.20	J, K	45	10	60	0.50	50
MI-321611-2R7	2.70	J, K	45	10	45	0.60	50
MI-321611-3R3	3.30	J, K	45	10	41	0.70	50
MI-321611-3R9	3.90	J, K	45	10	38	0.80	50
MI-321611-4R7	4.70	J, K	45	10	45	0.85	50
MI-321611-5R6	5.60	J, K	50	4	40	0.70	25
MI-321611-6R8	6.80	J, K	50	4	35	0.80	25
MI-321611-8R2	8.20	J, K	50	4	30	0.90	25
MI-321611-100	10.00	J, K	50	2	24	1.00	25
MI-321611-120	12.00	J, K	50	2	26	1.05	15
MI-321611-150	15.00	J, K	35	1	19	0.70	5
MI-321611-180	18.00	J, K	35	1	18	0.70	5
MI-321611-220	22.00	J, K	35	1	16	0.90	5
MI-321611-270	27.00	J, K	35	1	14	0.90	5
MI-321611-330	33.00	J, K	35	0.4	13	1.05	5

(J=5%, K=10%, M=20%)



ELECTRIC CHARACTERISTICS CURVES (MI-160808-SERIES)

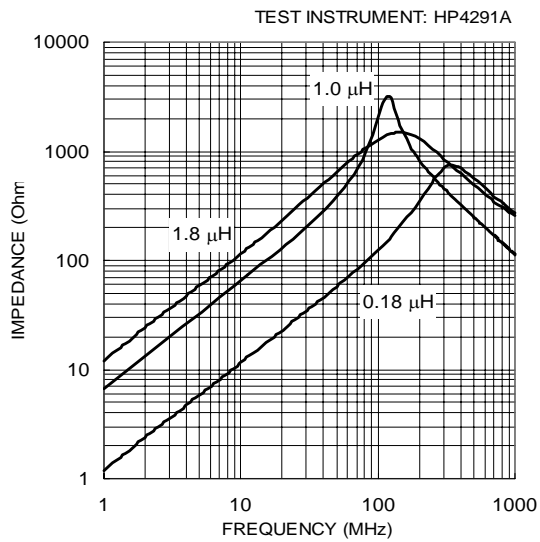
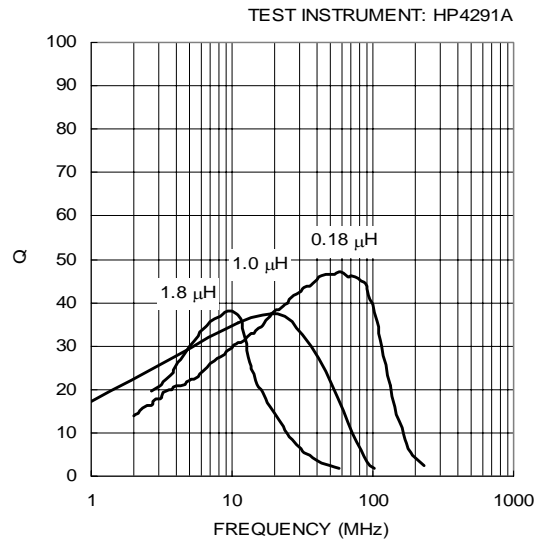
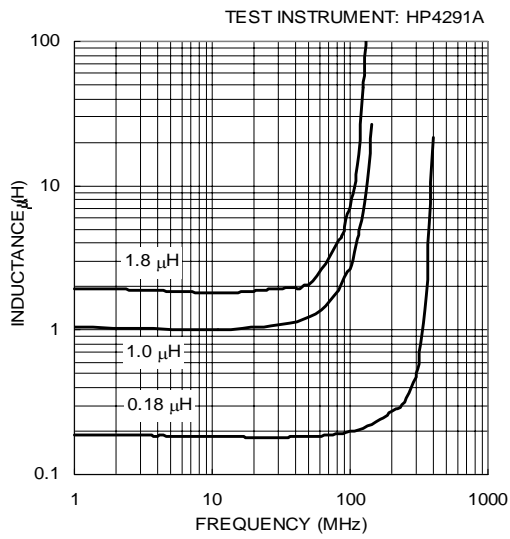



ELECTRIC CHARACTERISTICS CURVES (MI-201209-SERIES)

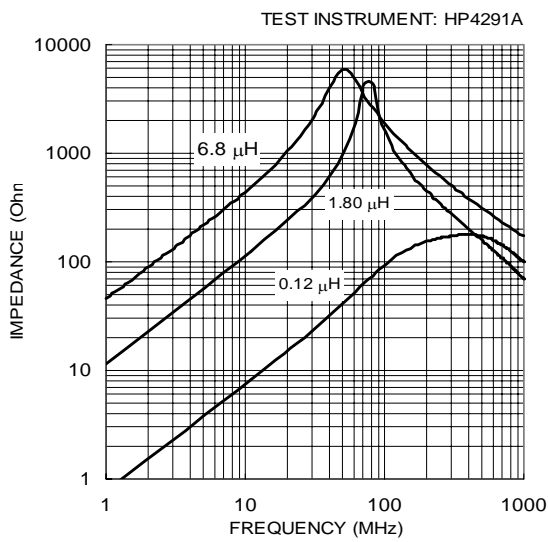
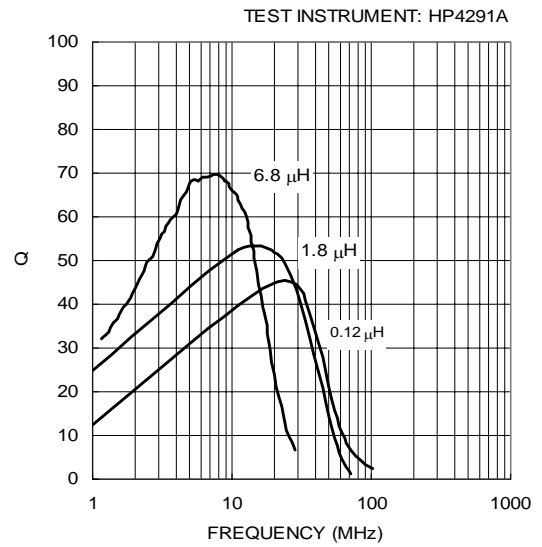
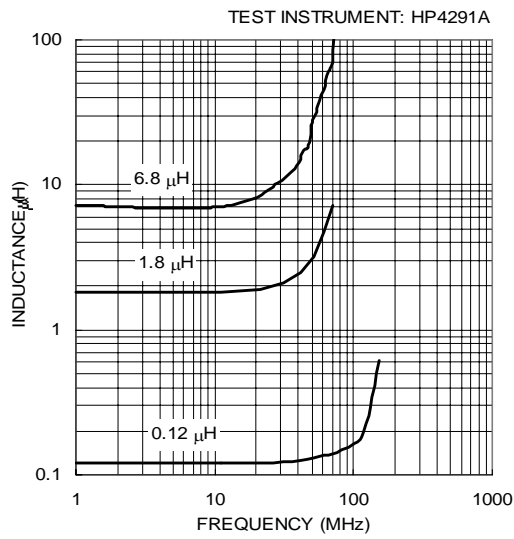



ELECTRIC CHARACTERISTICS CURVES (MI-321611-SERIES)

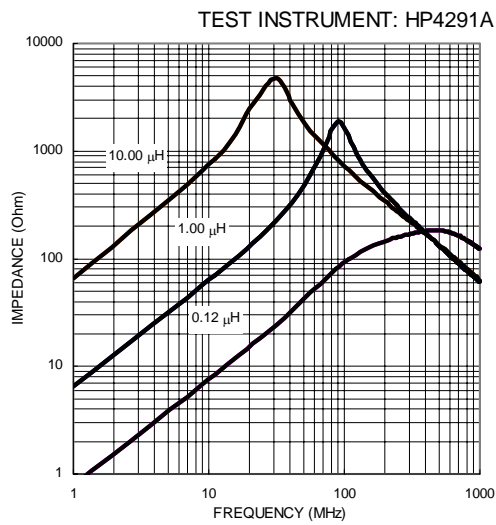
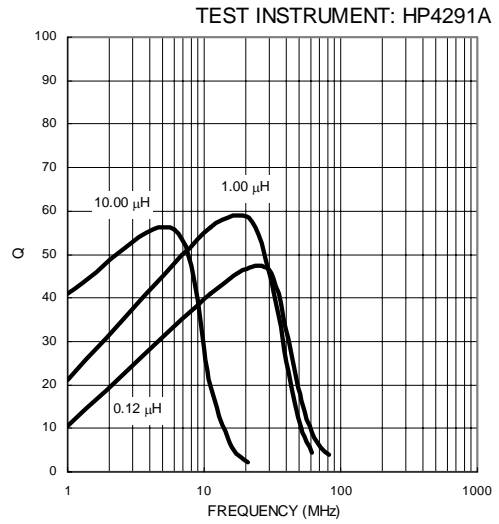
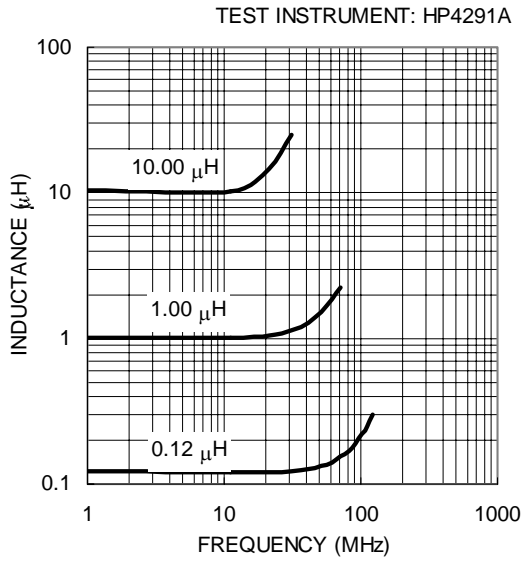

**MECHANICAL PERFORMANCE TEST (MULTILAYER CHIP INDUCTORS)**

ITEM	SPECIFICATION	TEST CONDITION																											
SOLDERABILITY	MORE THAN 90% OF THE TERMINAL ELECTRODE SHALL BE COVERED WITH FRESH SOLDER.	SOLDER: H63A (EUTECTIC SOLDER) SOLDER TEMPERATURE: 240 °C±5°C FLUX: ROSIN DIP TIME: 3 ± 1 SECONDS																											
SOLDERING HEAT RESISTANCE	THE CHIP SHALL NOT CRACK. MORE THAN 75% OF THE TERMINAL ELECTRODE SHALL BE COVERED WITH SOLDER.	SOLDER: H63A (EUTECTIC SOLDER) SOLDER TEMPERATURE: 260 °C±5°C FLUX: ROSIN DIP TIME: 10 ± 1 SECONDS																											
TERMINAL STRENGTH	THE TERMINAL ELECTRODE SHALL NOT BREAK OFF NOR THE FERRITE/CERAMIC DAMAGE.	<table border="1"> <thead> <tr> <th>TYPE</th> <th>KGF</th> <th>TIME (sec)</th> </tr> </thead> <tbody> <tr> <td>MI-100505</td> <td>0.3</td> <td>30±5</td> </tr> <tr> <td>MHI-100505</td> <td>0.3</td> <td>30±5</td> </tr> <tr> <td>MI-160808</td> <td>0.6</td> <td>30±5</td> </tr> <tr> <td>MHI-160808</td> <td>0.6</td> <td>30±5</td> </tr> <tr> <td>MI-201209</td> <td>0.6</td> <td>30±5</td> </tr> <tr> <td>MHI-201209</td> <td>0.6</td> <td>30±5</td> </tr> <tr> <td>MI-321611</td> <td>1.0</td> <td>30±5</td> </tr> <tr> <td>MI-322513</td> <td>1.0</td> <td>30±5</td> </tr> </tbody> </table>	TYPE	KGF	TIME (sec)	MI-100505	0.3	30±5	MHI-100505	0.3	30±5	MI-160808	0.6	30±5	MHI-160808	0.6	30±5	MI-201209	0.6	30±5	MHI-201209	0.6	30±5	MI-321611	1.0	30±5	MI-322513	1.0	30±5
TYPE	KGF	TIME (sec)																											
MI-100505	0.3	30±5																											
MHI-100505	0.3	30±5																											
MI-160808	0.6	30±5																											
MHI-160808	0.6	30±5																											
MI-201209	0.6	30±5																											
MHI-201209	0.6	30±5																											
MI-321611	1.0	30±5																											
MI-322513	1.0	30±5																											
BENDING STRENGTH	THE FERRITE / CERAMIC SHALL NOT BE DAMAGED BY FORCES APPLIED ON THE RIGHT CONDITION.	<table border="1"> <thead> <tr> <th>TYPE</th> <th>A (MM)</th> <th>KGF</th> </tr> </thead> <tbody> <tr> <td>MI-160808</td> <td>1.0</td> <td>0.6</td> </tr> <tr> <td>MHI-160808</td> <td>1.0</td> <td>0.6</td> </tr> <tr> <td>MI-201209</td> <td>1.4</td> <td>1.0</td> </tr> <tr> <td>MHI-201209</td> <td>1.4</td> <td>1.0</td> </tr> <tr> <td>MI-321611</td> <td>2.0</td> <td>2.0</td> </tr> <tr> <td>MI-322513</td> <td>2.0</td> <td>2.0</td> </tr> </tbody> </table>	TYPE	A (MM)	KGF	MI-160808	1.0	0.6	MHI-160808	1.0	0.6	MI-201209	1.4	1.0	MHI-201209	1.4	1.0	MI-321611	2.0	2.0	MI-322513	2.0	2.0						
TYPE	A (MM)	KGF																											
MI-160808	1.0	0.6																											
MHI-160808	1.0	0.6																											
MI-201209	1.4	1.0																											
MHI-201209	1.4	1.0																											
MI-321611	2.0	2.0																											
MI-322513	2.0	2.0																											

CLIMATIC TEST

ITEM	SPECIFICATION	TEST CONDITION
THERMAL SHOCK (TEMPERATURE CYCLE)	NO MECHANICAL DAMAGE. INDUCTANCE SHALL BE WITHIN ± 5% OF THE INITIAL VALUE, AND Q SHALL BE WITHIN ±30% OF THE INITIAL VALUE.	TEMPERATURE: -40 °C, +85 °C FOR 30 MINUTIES EACH, 100 CYCLES
HUMIDITY RESISTANCE		TEMPERATURE: + 40 °C HUMIDITY: 95% RH TIME: 1000 ± 12 HOURS
HIGH TEMPERATURE RESISTANCE		TEMPERATURE: + 85±2 °C TIME: 1000 ± 12 HOURS
LOW TEMPERATURE RESISTANCE		TEMPERATURE: + 40 °C ± 2 °C TIME: 1000 ± 12 HOURS



STANDARD PACKAGING (MULTILAYER CHIP INDUCTORS)

● TAPE DIMENSION

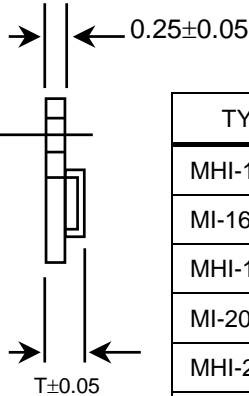
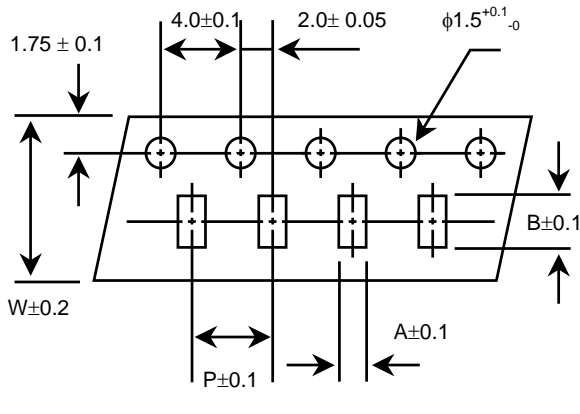

Dimension in mm

TYPE	A	B	W	P	T
MHI-100505	0.7	1.2	8	2	0.8
MI-160808	1.1	1.9	8	4	1.1
MHI-160808	1.1	1.9	8	4	1.1
MI-201209	1.5	2.3	8	4	1.3
MHI-201209	1.5	2.3	8	4	1.3
MI-321611	1.9	3.5	8	4	1.5

CARRIER TAPE MATERIAL: POLYSTYRENE

● REEL DIMENSION

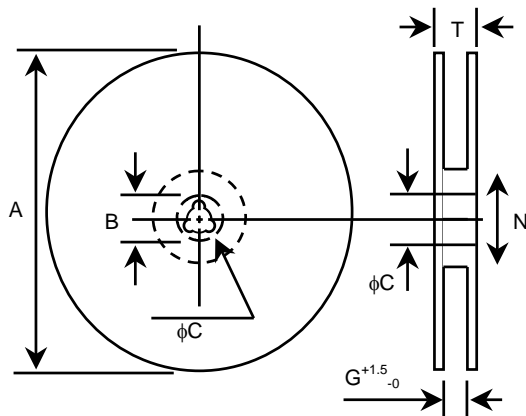

Dimension in mm

TYPE	Q'TY	A	B	C	G	N	T
MHI-100505	10000 PCS	178	21.0	13.0	8.4	55	12.4
MI-160808	4000 PCS	178	21.0	13.0	8.4	55	12.4
MHI-160808	4000 PCS	178	21.0	13.0	8.4	55	12.4
MI-201209	4000 PCS	178	21.0	13.0	8.4	55	12.4
MHI-201209	4000 PCS	178	21.0	13.0	8.4	55	12.4
MI-321611	3000 PCS	178	21.0	13.0	8.4	55	12.4

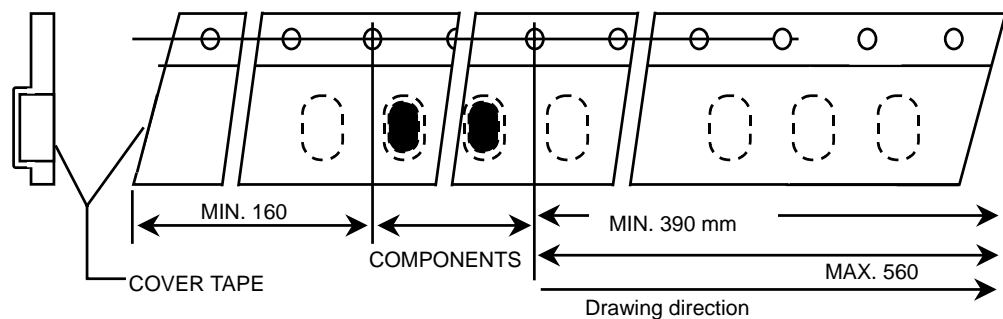

**MHI TYPE****PRODUCT IDENTIFICATION**

MHI	-	160808	-	1N5	S
1	2	3	4		

1. PRODUCT SYMBOLE
2. DIMENSION
3. INDUCTANCE
4. TOLERANCE (J=5%,K=10%,S=±0.3nH)

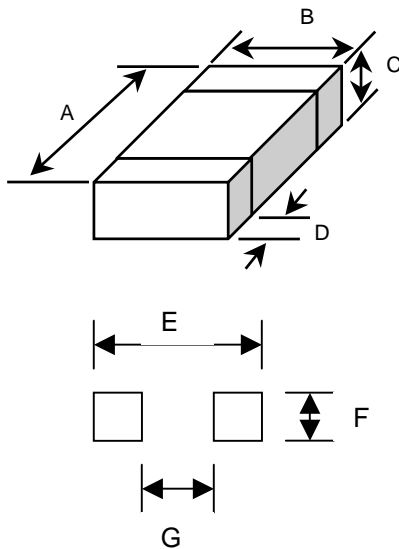
SHAPES, DIMENSIONS & RECOMMENDED PATTERN

Dimension in mm (inch)

PART NO.	DIMENSIONS				RECOMMENDED PATTERN		
	A	B	C	D	E	F	G
MHI-100505 (0402)	1.0 ± 0.10 (0.040±0.004)	0.5 ± 0.10 (0.020±0.004)	0.5 ± 0.10 (0.020±0.004)	0.2 ± 0.10 (0.008±0.004)	1.4 (0.055)	0.5 (0.020)	0.5 (0.020)
MHI-160808 (0603)	1.6 ± 0.15 (0.063±0.006)	0.8 ± 0.15 (0.031±0.006)	0.8 ± 0.15 (0.031±0.006)	0.3 ± 0.20 (0.012±0.008)	2.1 (0.083)	0.7 (0.028)	0.7 (0.028)
MHI-201209 (0805)	2.0 ± 0.20 (0.079±0.008)	1.2 ± 0.20 (0.047±0.008)	0.9 ± 0.20 (0.035±0.008)	0.5 ± 0.30 (0.020±0.012)	2.6 (0.102)	1.0 (0.039)	1.0 (0.039)



Part Number	Inductance (nH) at 100 MHz	Tolerance	Q Typical		SRF (GHz) Min.	DC Resistance (Ω) Max.	Rated Current (mA) Max.
			100MHz	800MHz			
MHI-100505-1N0	1.0	S	10	28	13.50	0.10	300
MHI-100505-1N2	1.2	S	9	28	12.00	0.10	300
MHI-100505-1N5	1.5	S	10	30	10.50	0.10	300
MHI-100505-1N8	1.8	S	10	28	9.40	0.10	300
MHI-100505-2N2	2.2	S	10	30	8.70	0.20	300
MHI-100505-2N7	2.7	S	10	30	7.70	0.20	300
MHI-100505-3N3	3.3	K, S	10	30	6.80	0.30	300
MHI-100505-3N9	3.9	K, S	11	31	6.30	0.30	300
MHI-100505-4N7	4.7	K, S	10	30	5.70	0.40	300
MHI-100505-5N6	5.6	K, S	11	31	5.10	0.40	300
MHI-100505-6N8	6.8	J, K	10	31	4.55	0.50	300
MHI-100505-8N2	8.2	J, K	12	34	4.10	0.50	300
MHI-100505-10N	10.0	J, K	12	32	3.75	0.60	300
MHI-100505-12N	12.0	J, K	12	31	2.95	0.60	300
MHI-100505-15N	15.0	J, K	11	30	2.60	0.70	300
MHI-100505-18N	18.0	J, K	11	29	2.35	0.80	300
MHI-100505-22N	22.0	J, K	11	28	1.95	0.90	300
MHI-100505-27N	27.0	J, K	12	27	1.75	1.00	300
MHI-100505-33N	33.0	J, K	10	25	1.70	1.50	200
MHI-100505-39N	39.0	J, K	10	25	1.65	1.80	200
MHI-100505-47N	47.0	J, K	9	23	1.30	2.00	200

(J=5%, K=10%, S= ± 0.3 nH)



Part Number	Inductance (nH) at 100 MHz	Tolerance	Q Typical		SRF (GHz) Min.	DC Resistance (Ω) Max.	Rated Current (mA) Max.
			100MHz	800MHz			
MHI-160808-1N2	1.2	S	13	60	>6.00	0.12	300
MHI-160808-1N5	1.5	S	13	47	>6.00	0.12	300
MHI-160808-1N8	1.8	S	12	51	>6.00	0.12	300
MHI-160808-2N2	2.2	S	12	38	>6.00	0.16	300
MHI-160808-2N7	2.7	S	12	38	>6.00	0.20	300
MHI-160808-3N3	3.3	K, S	12	41	5.70	0.22	300
MHI-160808-3N9	3.9	K, S	13	50	5.60	0.25	300
MHI-160808-4N7	4.7	K, S	12	41	4.80	0.28	300
MHI-160808-5N6	5.6	K, S	12	42	4.35	0.29	300
MHI-160808-6N8	6.8	J, K	12	40	3.75	0.30	300
MHI-160808-8N2	8.2	J, K	13	34	3.30	0.33	300
MHI-160808-10N	10.0	J, K	13	45	2.85	0.35	300
MHI-160808-12N	12.0	J, K	15	46	2.70	0.40	300
MHI-160808-15N	15.0	J, K	15	48	2.40	0.45	300
MHI-160808-18N	18.0	J, K	16	48	2.05	0.50	300
MHI-160808-22N	22.0	J, K	17	45	1.85	0.55	300
MHI-160808-27N	27.0	J, K	17	43	1.75	0.60	300
MHI-160808-33N	33.0	J, K	18	39	1.50	0.65	300
MHI-160808-39N	39.0	J, K	17	37	1.35	0.70	300
MHI-160808-47N	47.0	J, K	17	35	1.20	0.90	300
MHI-160808-56N	56.0	J, K	17	32	1.10	1.00	300
MHI-160808-68N	68.0	J, K	18	34	1.00	1.50	300
MHI-160808-82N	82.0	J, K	18	32	0.90	1.80	300
MHI-160808-R10	100.0	J, K	15	16	0.83	2.10	300

(J=5%, K=10%, S= \pm 0.3nH)



Part Number	Inductance (nH) at 100 MHz	Tolerance	Q Typical		SRF (GHz) Min.	DC Resistance (Ω) Max.	Rated Current (mA) Max.
			100MHz	800MHz			
MHI-201209-1N5	1.5	S	16	55	4.00	0.10	300
MHI-201209-1N8	1.8	S	16	55	4.00	0.10	300
MHI-201209-2N2	2.2	S	16	51	4.00	0.10	300
MHI-201209-2N7	2.7	S	16	55	4.00	0.10	300
MHI-201209-3N3	3.3	K, S	19	65	4.00	0.13	300
MHI-201209-3N9	3.9	K, S	19	65	3.00	0.15	300
MHI-201209-4N7	4.7	K, S	19	65	3.00	0.20	300
MHI-201209-5N6	5.6	K, S	19	62	3.00	0.23	300
MHI-201209-6N8	6.8	J, K	19	55	2.50	0.25	300
MHI-201209-8N2	8.2	J, K	19	53	2.00	0.28	300
MHI-201209-10N	10.0	J, K	20	60	2.00	0.30	300
MHI-201209-12N	12.0	J, K	20	40	1.50	0.35	300
MHI-201209-15N	15.0	J, K	20	48	1.50	0.40	300
MHI-201209-18N	18.0	J, K	20	54	1.30	0.45	300
MHI-201209-22N	22.0	J, K	20	38	1.20	0.50	300
MHI-201209-27N	27.0	J, K	20	38	1.00	0.55	300
MHI-201209-33N	33.0	J, K	20	28	1.00	0.60	300
MHI-201209-39N	39.0	J, K	20	21	0.80	0.65	300
MHI-201209-47N	47.0	J, K	21	17	0.80	0.70	300
MHI-201209-56N	56.0	J, K	21	12	0.70	0.75	300
MHI-201209-68N	68.0	J, K	21	9	0.60	0.80	300
MHI-201209-82N	82.0	J, K	22	4	0.50	0.90	300
MHI-201209-R10	100.0	J, K	22	16	0.50	0.90	300
MHI-201209-R12	120.0	J, K	22	20	0.40	0.95	300
MHI-201209-R15	150.0	J, K	22	—	0.30	1.00	300
MHI-201209-R18	180.0	J, K	21	—	0.30	1.10	300
MHI-201209-R22	220.0	J, K	20	—	0.30	1.20	300
MHI-201209-R27	270.0	J, K	24	—	0.20	1.30	300
MHI-201209-R33	330.0	J, K	24	—	0.20	1.05	300
MHI-201209-R39	390.0	J, K	24	—	0.20	1.50	300
MHI-201209-R47	470.0	J, K	24	—	0.20	1.50	300

(J=5%, K=10%, S=±0.3nH)



ELECTRIC CHARACTERISTICS CURVES (MHI-100505 SERIES)

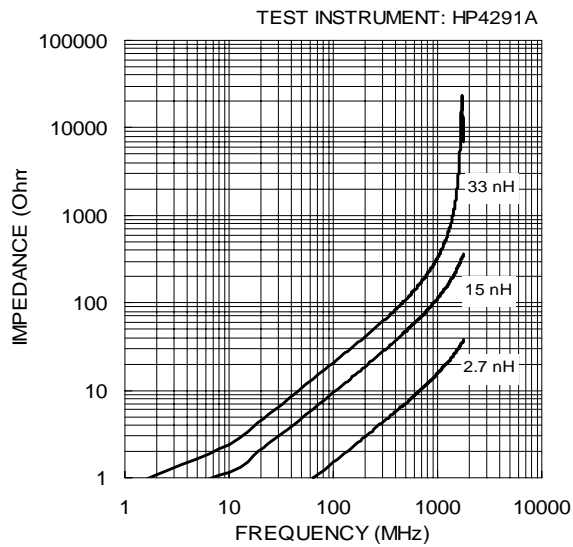
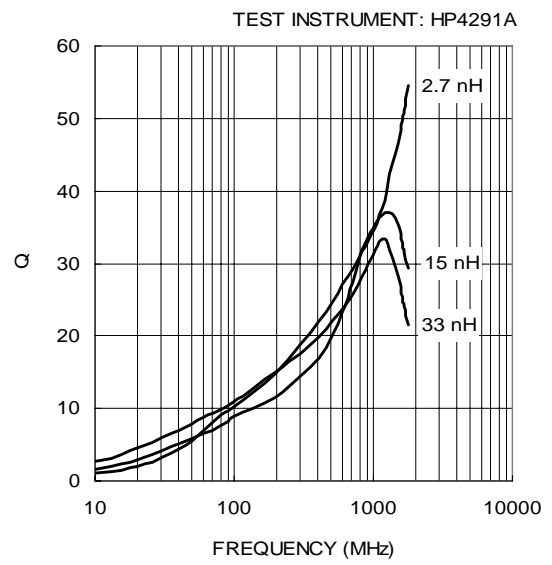
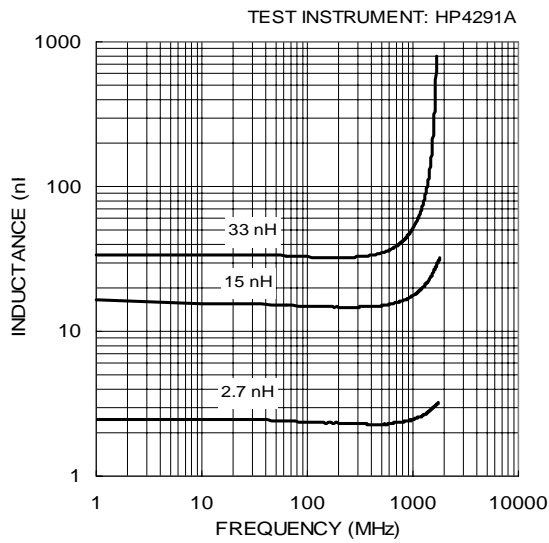



ELECTRIC CHARACTERISTICS CURVES (MHI-160808 SERIES)

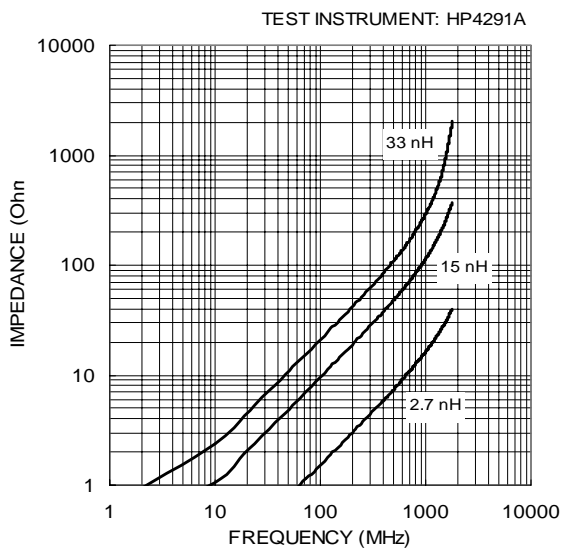
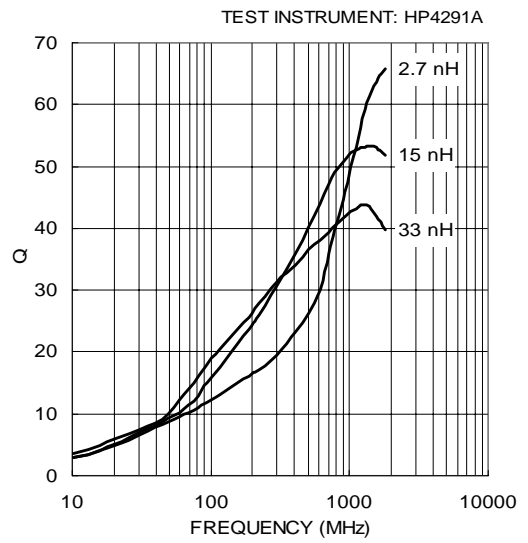
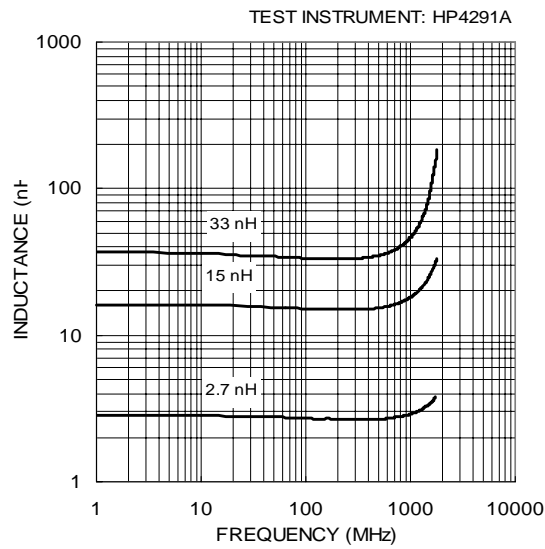



ELECTRIC CHARACTERISTICS CURVES (MHI-201209 SERIES)

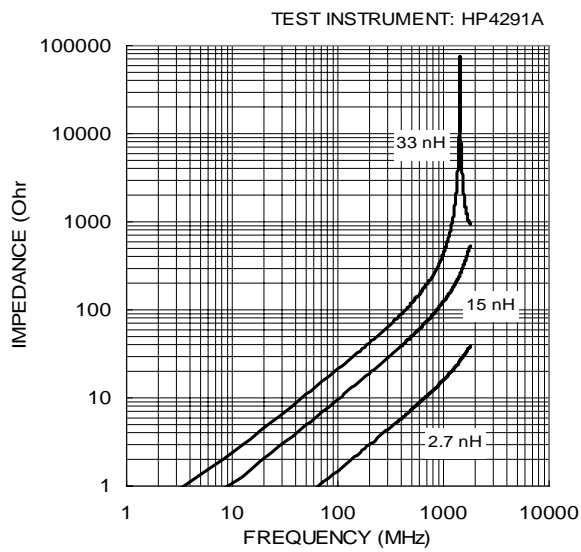
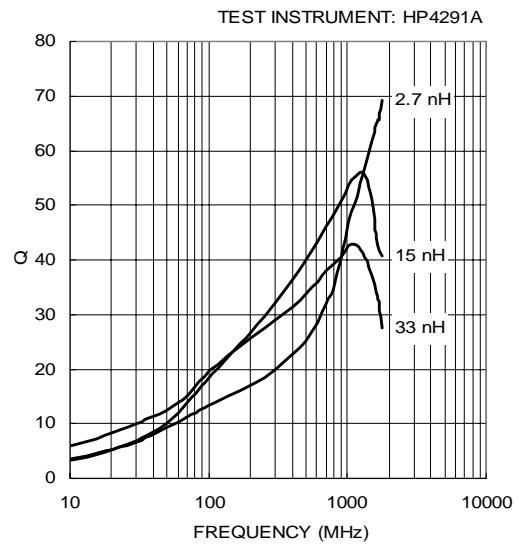
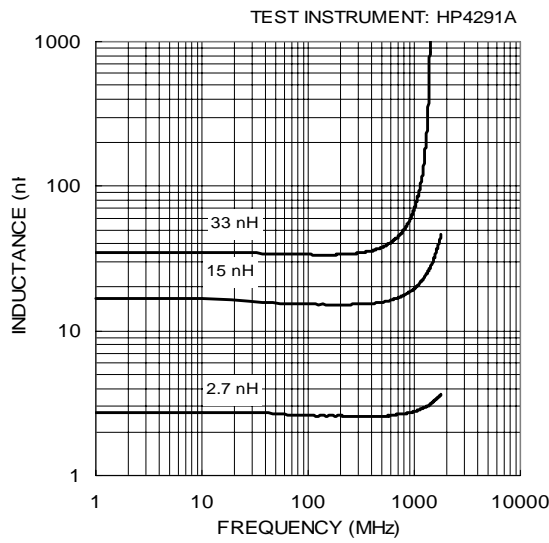

**MECHANICAL PERFORMANCE TEST (MULTILAYER CHIP INDUCTORS)**

ITEM	SPECIFICATION	TEST CONDITION																											
SOLDERABILITY	MORE THAN 90% OF THE TERMINAL ELECTRODE SHALL BE COVERED WITH FRESH SOLDER.	SOLDER: H63A (EUTECTIC SOLDER) SOLDER TEMPERATURE: 240 °C±5°C FLUX: ROSIN DIP TIME: 3 ± 1 SECONDS																											
SOLDERING HEAT RESISTANCE	THE CHIP SHALL NOT CRACK. MORE THAN 75% OF THE TERMINAL ELECTRODE SHALL BE COVERED WITH SOLDER.	SOLDER: H63A (EUTECTIC SOLDER) SOLDER TEMPERATURE: 260 °C±5°C FLUX: ROSIN DIP TIME: 10 ± 1 SECONDS																											
TERMINAL STRENGTH	THE TERMINAL ELECTRODE SHALL NOT BREAK OFF NOR THE FERRITE/CERAMIC DAMAGE.	<table border="1"> <thead> <tr> <th>TYPE</th> <th>KGF</th> <th>TIME (sec)</th> </tr> </thead> <tbody> <tr> <td>MI-100505</td> <td>0.3</td> <td>30±5</td> </tr> <tr> <td>MHI-100505</td> <td>0.3</td> <td>30±5</td> </tr> <tr> <td>MI-160808</td> <td>0.6</td> <td>30±5</td> </tr> <tr> <td>MHI-160808</td> <td>0.6</td> <td>30±5</td> </tr> <tr> <td>MI-201209</td> <td>0.6</td> <td>30±5</td> </tr> <tr> <td>MHI-201209</td> <td>0.6</td> <td>30±5</td> </tr> <tr> <td>MI-321611</td> <td>1.0</td> <td>30±5</td> </tr> <tr> <td>MI-322513</td> <td>1.0</td> <td>30±5</td> </tr> </tbody> </table>	TYPE	KGF	TIME (sec)	MI-100505	0.3	30±5	MHI-100505	0.3	30±5	MI-160808	0.6	30±5	MHI-160808	0.6	30±5	MI-201209	0.6	30±5	MHI-201209	0.6	30±5	MI-321611	1.0	30±5	MI-322513	1.0	30±5
TYPE	KGF	TIME (sec)																											
MI-100505	0.3	30±5																											
MHI-100505	0.3	30±5																											
MI-160808	0.6	30±5																											
MHI-160808	0.6	30±5																											
MI-201209	0.6	30±5																											
MHI-201209	0.6	30±5																											
MI-321611	1.0	30±5																											
MI-322513	1.0	30±5																											
BENDING STRENGTH	THE FERRITE / CERAMIC SHALL NOT BE DAMAGED BY FORCES APPLIED ON THE RIGHT CONDITION.	<table border="1"> <thead> <tr> <th>TYPE</th> <th>A (MM)</th> <th>KGF</th> </tr> </thead> <tbody> <tr> <td>MI-160808</td> <td>1.0</td> <td>0.6</td> </tr> <tr> <td>MHI-160808</td> <td>1.0</td> <td>0.6</td> </tr> <tr> <td>MI-201209</td> <td>1.4</td> <td>1.0</td> </tr> <tr> <td>MHI-201209</td> <td>1.4</td> <td>1.0</td> </tr> <tr> <td>MI-321611</td> <td>2.0</td> <td>2.0</td> </tr> <tr> <td>MI-322513</td> <td>2.0</td> <td>2.0</td> </tr> </tbody> </table>	TYPE	A (MM)	KGF	MI-160808	1.0	0.6	MHI-160808	1.0	0.6	MI-201209	1.4	1.0	MHI-201209	1.4	1.0	MI-321611	2.0	2.0	MI-322513	2.0	2.0						
TYPE	A (MM)	KGF																											
MI-160808	1.0	0.6																											
MHI-160808	1.0	0.6																											
MI-201209	1.4	1.0																											
MHI-201209	1.4	1.0																											
MI-321611	2.0	2.0																											
MI-322513	2.0	2.0																											

CLIMATIC TEST

ITEM	SPECIFICATION	TEST CONDITION
THERMAL SHOCK (TEMPERATURE CYCLE)	NO MECHANICAL DAMAGE. INDUCTANCE SHALL BE WITHIN ± 5% OF THE INITIAL VALUE, AND Q SHALL BE WITHIN ±30% OF THE INITIAL VALUE.	TEMPERATURE: -40 °C, +85 °C FOR 30 MINUTIES EACH, 100 CYCLES
HUMIDITY RESISTANCE		TEMPERATURE: + 40 °C HUMIDITY: 95% RH TIME: 1000 ± 12 HOURS
HIGH TEMPERATURE RESISTANCE		TEMPERATURE: + 85±2 °C TIME: 1000 ± 12 HOURS
LOW TEMPERATURE RESISTANCE		TEMPERATURE: + 40 °C ± 2 °C TIME: 1000 ± 12 HOURS



STANDARD PACKAGING (MULTILAYER CHIP INDUCTORS)

● TAPE DIMENSION

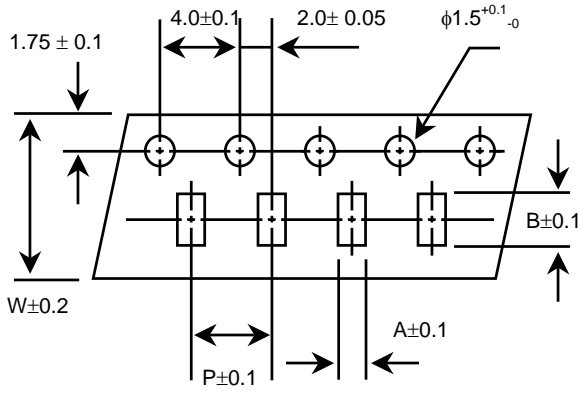

Dimension in mm

TYPE	A	B	W	P	T
MHI-100505	0.7	1.2	8	2	0.8
MI-160808	1.1	1.9	8	4	1.1
MHI-160808	1.1	1.9	8	4	1.1
MI-201209	1.5	2.3	8	4	1.3
MHI-201209	1.5	2.3	8	4	1.3
MI-321611	1.9	3.5	8	4	1.5

CARRIER TAPE MATERIAL: POLYSTYRENE

● REEL DIMENSION

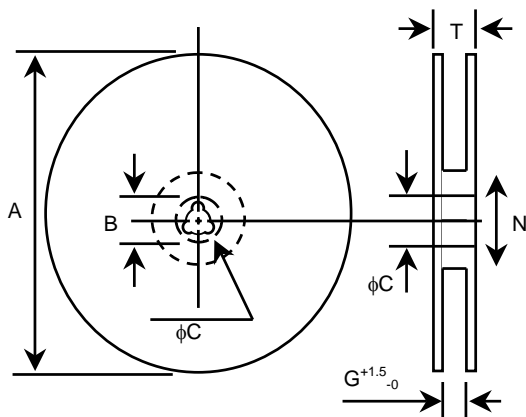

Dimension in mm

TYPE	Q'TY	A	B	C	G	N	T
MHI-100505	10000 PCS	178	21.0	13.0	8.4	55	12.4
MI-160808	4000 PCS	178	21.0	13.0	8.4	55	12.4
MHI-160808	4000 PCS	178	21.0	13.0	8.4	55	12.4
MI-201209	4000 PCS	178	21.0	13.0	8.4	55	12.4
MHI-201209	4000 PCS	178	21.0	13.0	8.4	55	12.4
MI-321611	3000 PCS	178	21.0	13.0	8.4	55	12.4

