



WB TYPE

PRODUCT IDENTIFICATION

<table border="1"> <tr> <td>WB</td> <td>-</td> <td>40</td> <td>30</td> <td>25</td> </tr> <tr> <td>1</td> <td>2</td> <td>3</td> <td>4</td> <td></td> </tr> </table>	WB	-	40	30	25	1	2	3	4		<ol style="list-style-type: none"> 1. PRODUCT SYMBOLE 2. DIMENSION (A) 3. DIMENSION (B) 4. DIMENSION (C)
WB	-	40	30	25							
1	2	3	4								

SHAPES & DIMENSIONS

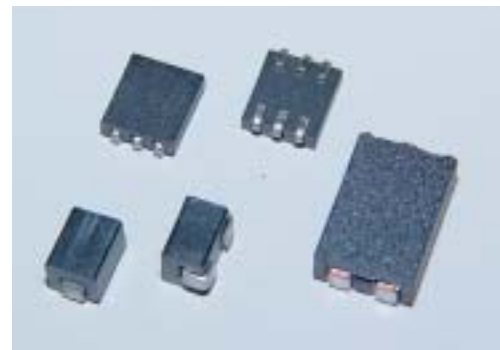
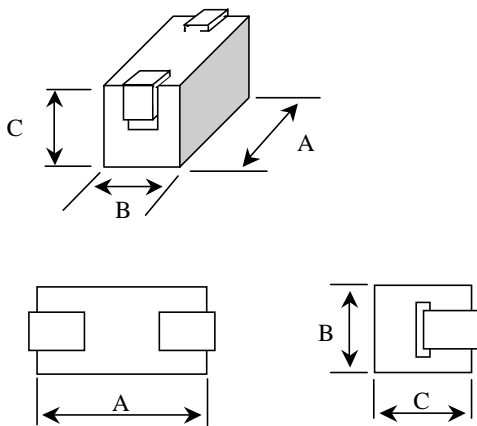

PART NO.	DIMENSIONS (mm)				IMPEDANCE (Ω)		DC RESISTANCE (m Ω) MAX.
	A	B	C	D	25 MHz	100 MHz	
WB-403025	4.00 \pm 0.15	3.10 \pm 0.10	2.54 \pm 0.10	1.35 \pm 0.20	30 MIN.	47 \pm 20%	0.6
WB-853025	8.50 \pm 0.15	3.10 \pm 0.10	2.54 \pm 0.10	2.00 \pm 0.20	60 MIN.	90 \pm 20%	0.9

ELECTRIC CHARACTERISTICS

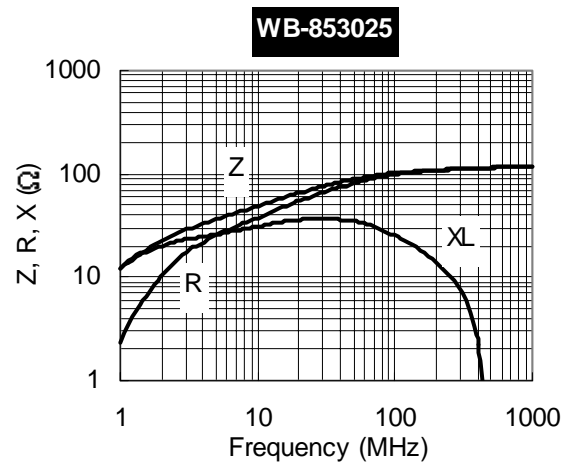
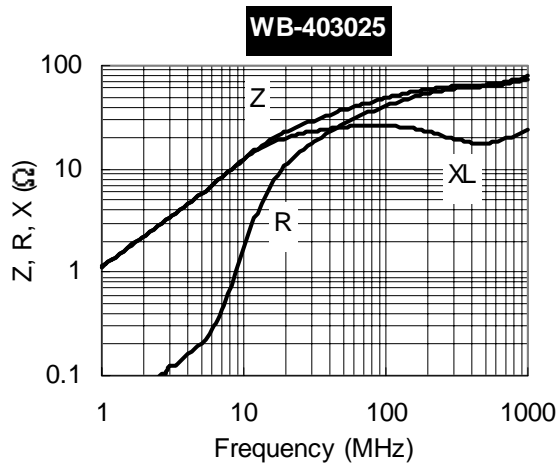



STANDARD PACKAGING (WOUND CHIP BEADS)

● TAPE DIMENSION

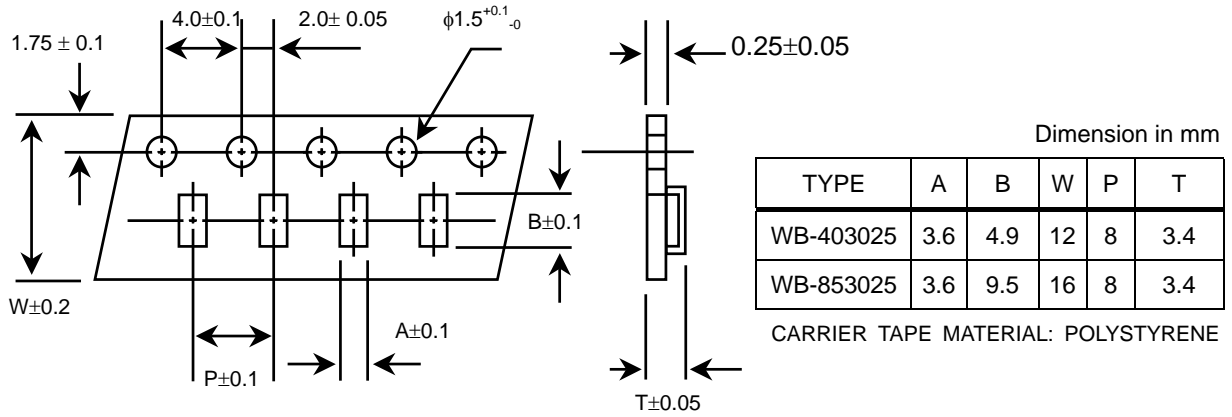

● REEL DIMENSION

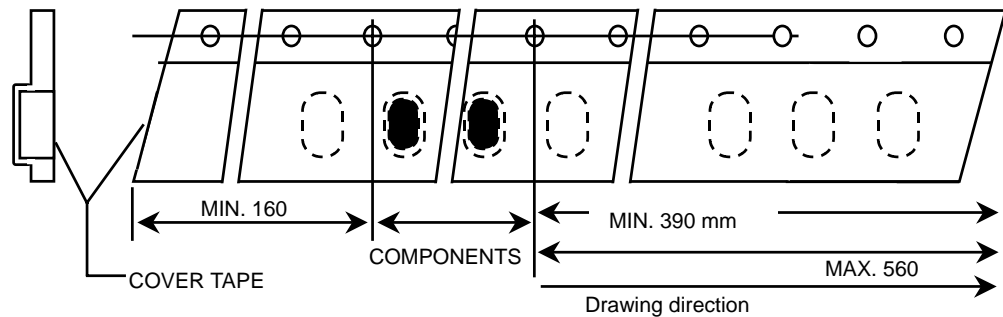
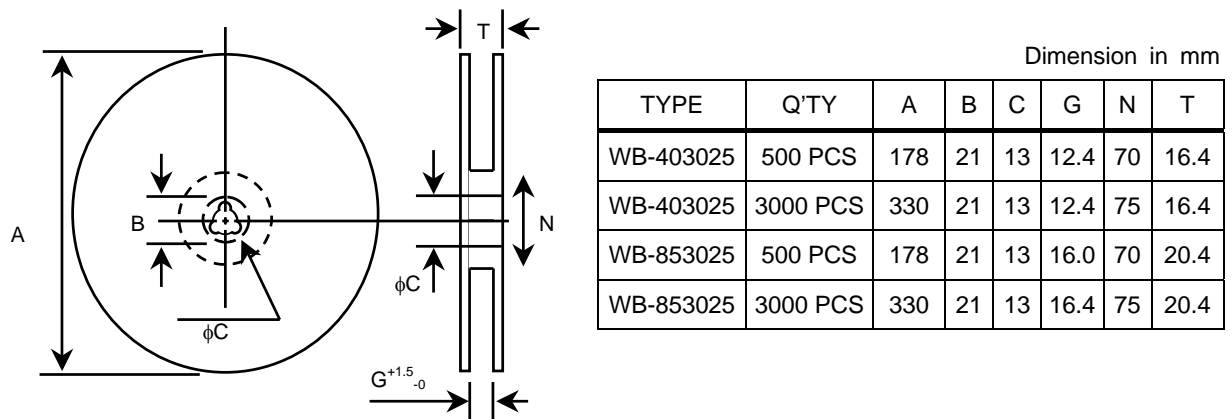



WI TYPE

PRODUCT IDENTIFICATION

$\frac{WI - 453232 - R10 M}{1 \quad 2 \quad 3 \quad 4}$	<ol style="list-style-type: none"> 1. PRODUCT SYMBOLE 2. DIMENSION 3. INDUCTANCE 4. TOLERANCE (J=5%, K=10%, M=20%)
---	--

SHAPES & DIMENSIONS

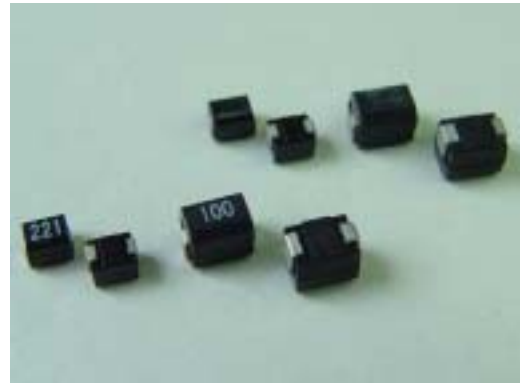
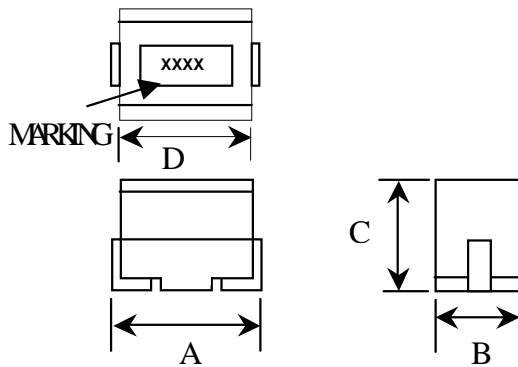

PART NO.	A	B	C	D
WI-322522	3.20 ± 0.30	2.50 ± 0.20	2.20 ± 0.20	2.90 ± 0.20
WI-453232	4.50 ± 0.30	3.20 ± 0.20	3.20 ± 0.20	4.20 ± 0.20

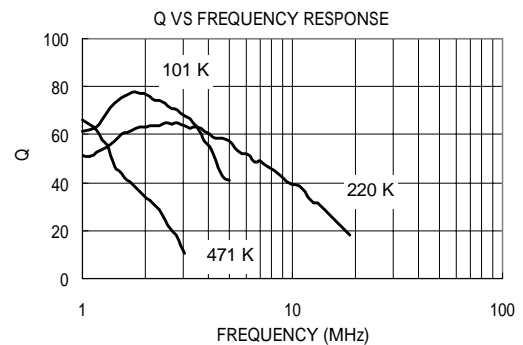
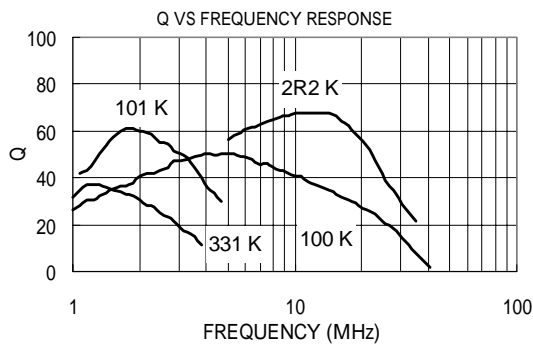
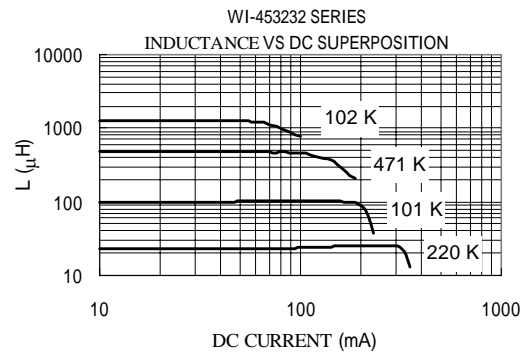
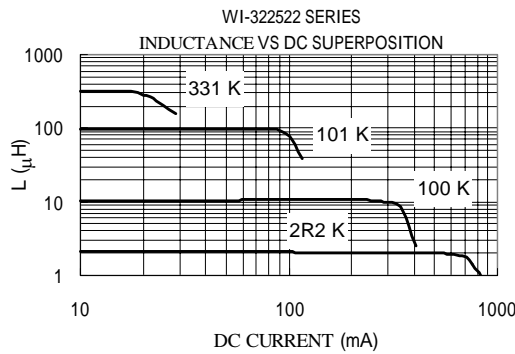



Part Number	Inductance (μ H)	Q Min.	L, Q Test Frequency (MHz)	SRF (MHz) Min.	DC Resistance (Ω) Max.	Rated Current (mA) Max.
WI-322522-R12	0.12	30	25.2	500	0.220	450
WI-322522-R15	0.15	30	25.2	450	0.250	450
WI-322522-R18	0.18	30	25.2	400	0.280	450
WI-322522-R22	0.22	30	25.2	350	0.320	450
WI-322522-R27	0.27	30	25.2	320	0.360	450
WI-322522-R33	0.33	30	25.2	300	0.400	450
WI-322522-R39	0.39	30	25.2	250	0.450	450
WI-322522-R47	0.47	30	25.2	220	0.500	450
WI-322522-R56	0.56	30	25.2	180	0.550	450
WI-322522-R68	0.68	30	25.2	160	0.600	450
WI-322522-R82	0.82	30	25.2	140	0.650	450
WI-322522-1R0	1.00	30	7.96	120	0.700	400
WI-322522-1R2	1.20	30	7.96	100	0.750	390
WI-322522-1R5	1.50	30	7.96	85	0.850	370
WI-322522-1R8	1.80	30	7.96	80	0.900	350
WI-322522-2R2	2.20	30	7.96	75	1.000	320
WI-322522-2R7	2.70	30	7.96	70	1.100	290
WI-322522-3R3	3.30	30	7.96	60	1.200	260
WI-322522-3R9	3.90	30	7.96	55	1.300	250
WI-322522-4R7	4.70	30	7.96	50	1.500	220
WI-322522-5R6	5.60	30	7.96	47	1.600	200
WI-322522-6R8	6.80	30	7.96	43	1.800	180
WI-322522-8R2	8.20	30	7.96	40	2.000	170
WI-322522-100	10.00	30	2.52	36	2.100	150
WI-322522-120	12.00	30	2.52	33	2.500	140
WI-322522-150	15.00	30	2.52	28	2.800	130
WI-322522-180	18.00	30	2.52	25	3.300	120
WI-322522-220	22.00	30	2.52	23	3.700	110
WI-322522-270	27.00	30	2.52	18	5.000	80
WI-322522-330	33.00	30	2.52	17	5.600	70
WI-322522-390	39.00	30	2.52	16	6.400	65
WI-322522-470	47.00	30	2.52	15	7.000	60

(J=5%, K=10%, M=20%)



Part Number	Inductance (μ H)	Q Min.	L, Q Test Frequency (MHz)	SRF (MHz) Min.	DC Resistance (Ω) Max.	Rated Current (mA) Max.
WI-322522-560	56.00	30	2.52	13	8.000	55
WI-322522-680	68.00	30	2.52	12	9.000	50
WI-322522-820	82.00	30	2.52	11	10.000	45
WI-322522-101	100.00	20	0.796	10	11.000	40
WI-322522-121	120.00	20	0.796	10	12.000	70
WI-322522-151	150.00	20	0.796	8.0	15.000	65
WI-322522-181	180.00	20	0.796	7.0	17.000	60
WI-322522-221	220.00	20	0.796	7.0	21.000	50

(J=5%, K=10%, M=20%)



Part Number	Inductance (μ H)	Q Min.	L, Q Test Frequency (MHz)	SRF (MHz) Min.	DC Resistance (Ω) Max.	Rated Current (mA) Max.
WI-453232-R10	0.10	35	25.2	300	0.180	800
WI-453232-R12	0.12	35	25.2	280	0.200	770
WI-453232-R15	0.15	35	25.2	250	0.220	730
WI-453232-R18	0.18	35	25.2	220	0.240	700
WI-453232-R22	0.22	40	25.2	200	0.250	665
WI-453232-R27	0.27	40	25.2	180	0.260	635
WI-453232-R33	0.33	40	25.2	165	0.280	605
WI-453232-R39	0.39	40	25.2	150	0.300	575
WI-453232-R47	0.47	40	25.2	145	0.320	545
WI-453232-R56	0.56	40	25.2	140	0.360	520
WI-453232-R68	0.68	40	25.2	135	0.400	500
WI-453232-R82	0.82	40	25.2	130	0.450	475
WI-453232-1R0	1.00	50	7.96	100	0.500	450
WI-453232-1R2	1.20	50	7.96	80	0.550	430
WI-453232-1R5	1.50	50	7.96	70	0.600	410
WI-453232-1R8	1.80	50	7.96	60	0.650	390
WI-453232-2R2	2.20	50	7.96	55	0.700	380
WI-453232-2R7	2.70	50	7.96	50	0.750	370
WI-453232-3R3	3.30	50	7.96	45	0.800	355
WI-453232-3R9	3.90	50	7.96	40	0.900	330
WI-453232-4R7	4.70	50	7.96	35	1.000	315
WI-453232-5R6	5.60	50	7.96	33	1.100	300
WI-453232-6R8	6.80	50	7.96	27	1.200	285
WI-453232-8R2	8.20	50	7.96	25	1.400	270
WI-453232-100	10.00	50	2.52	20	1.600	250
WI-453232-120	12.00	50	2.52	18	2.000	225
WI-453232-150	15.00	50	2.52	17	2.500	200
WI-453232-180	18.00	50	2.52	15	2.800	190
WI-453232-220	22.00	50	2.52	13	3.200	180
WI-453232-270	27.00	50	2.52	12	3.600	170
WI-453232-330	33.00	50	2.52	11	4.000	160
WI-453232-390	39.00	50	2.52	10	4.500	150

(J=5%, K=10%, M=20%)



Part Number	Inductance (μ H)	Q Min.	L, Q Test Frequency (MHz)	SRF (MHz) Min.	DC Resistance (Ω) Max.	Rated Current (mA) Max.
WI-453232-470	47.00	50	2.52	10	5.000	140
WI-453232-560	56.00	50	2.52	9.0	5.500	135
WI-453232-680	68.00	50	2.52	9.0	6.000	130
WI-453232-820	82.00	50	2.52	8.0	7.000	120
WI-453232-101	100.00	40	0.796	8.0	8.000	110
WI-453232-121	120.00	40	0.796	6.0	8.000	110
WI-453232-151	150.00	40	0.796	5.0	9.000	105
WI-453232-181	180.00	40	0.796	5.0	9.500	102
WI-453232-221	220.00	40	0.796	4.0	10.000	100
WI-453232-271	270.00	40	0.76	4.0	12.000	92
WI-453232-331	330.00	40	0.796	3.5	14.000	85
WI-453232-391	390.00	40	0.796	3.0	18.000	80
WI-453232-471	470.00	40	0.796	3.0	26.000	62
WI-453232-561	560.00	30	0.796	3.0	30.000	50
WI-453232-681	680.00	30	0.796	3.0	30.000	50
WI-453232-821	820.00	30	0.796	2.5	35.000	30
WI-453232-102	1.00 mH	20	0.252	2.5	40.000	30

(J=5%, K=10%, M=20%)



STANDARD PACAKAGING (WOUND CHIP INDUCTORS)

- TAPE DIMENSION

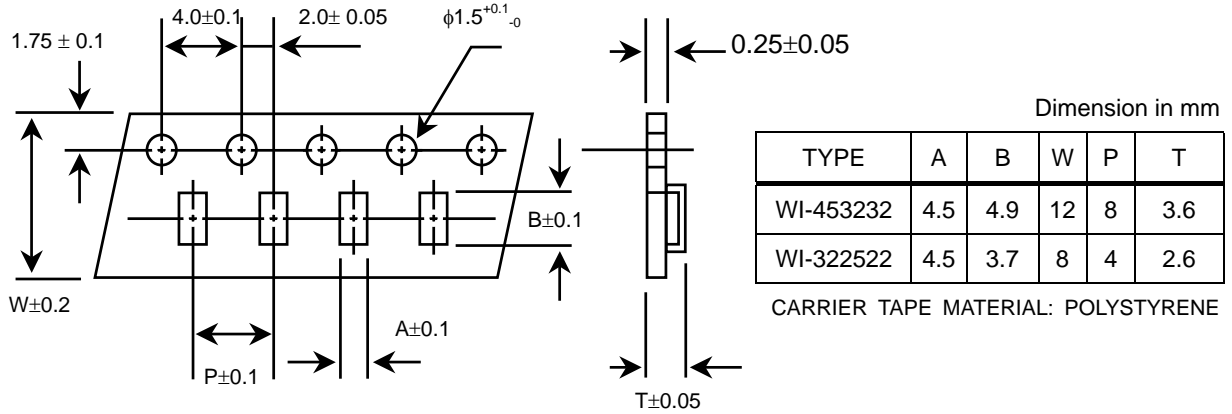

- REEL DIMENSION

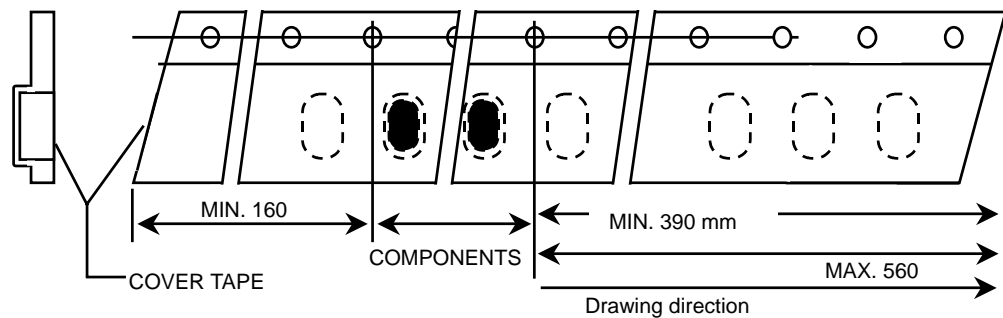
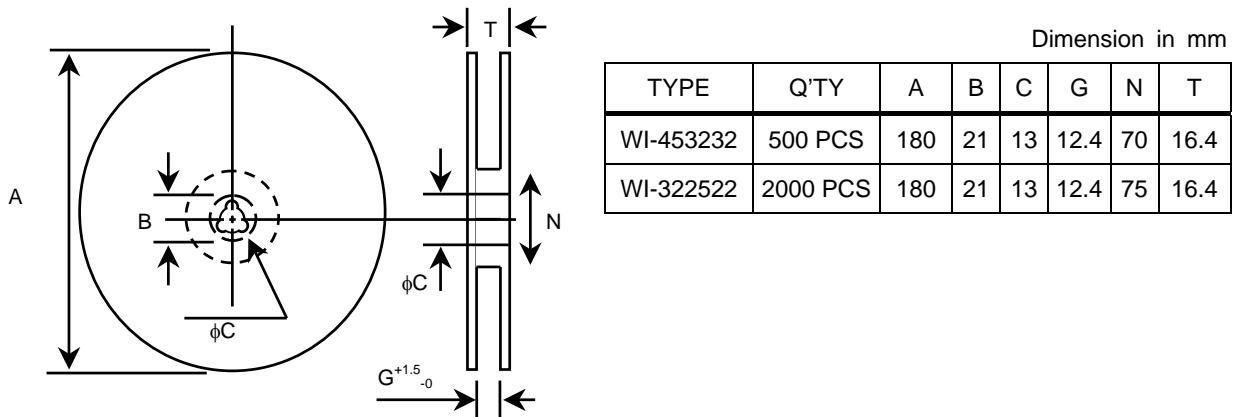



WIC TYPE

PRODUCT IDENTIFICATION

$\frac{\text{WIC} - 453232 - \text{R10} \text{ M}}{1 \quad 2 \quad 3 \quad 4}$	<ol style="list-style-type: none"> 1. PRODUCT SYMBOLE 2. DIMENSION 3. INDUCTANCE 4. TOLERANCE (J=5%, K=10%, M=20%)
--	--

SHAPES & DIMENSIONS

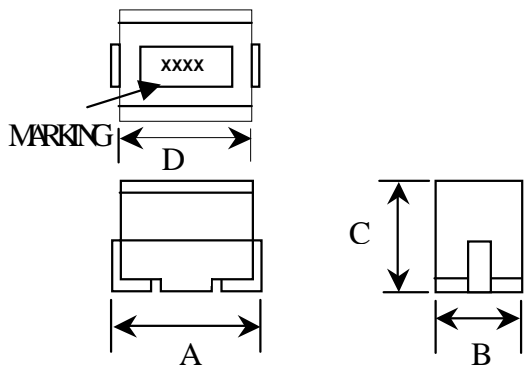

PART NO.	A	B	C	D
WIC-322522	3.20 ± 0.30	2.50 ± 0.20	2.20 ± 0.20	2.90 ± 0.20
WIC-453232	4.50 ± 0.30	3.20 ± 0.20	3.20 ± 0.20	4.20 ± 0.20



Part Number	Inductance (μ H)	Q Min.	L, Q Test Frequency (MHz)	SRF (MHz) Min.	DC Resistance (Ω) Max.	Rated Current (mA) Max.
WIC-322522-1R0	1.00	10	7.96	100	0.156	770
WIC-322522-1R5	1.50	10	7.96	80	0.195	580
WIC-322522-2R2	2.20	10	7.96	65	0.260	480
WIC-322522-3R3	3.30	10	7.96	55	0.325	400
WIC-322522-4R7	4.70	10	7.96	45	0.520	320
WIC-322522-6R8	6.80	10	7.96	35	0.650	280
WIC-322522-100	10.00	15	2.52	28	1.105	220
WIC-322522-150	15.00	15	2.52	25	1.690	180
WIC-322522-220	22.00	15	2.52	20	2.06	145
WIC-322522-270	27.00	15	2.52	17	3.00	125
WIC-322522-330	33.00	15	2.52	15	3.64	115
WIC-322522-470	47.00	20	2.52	13	5.46	105
WIC-322522-680	68.00	20	2.52	10	8.45	85
WIC-322522-820	82.00	20	2.52	9	8.71	80
WIC-322522-101	100.00	20	0.796	8	10.14	75

(J=5%, K=10%, M=20%)



Part Number	Inductance (μ H)	Q Min.	L, Q Test Frequency (MHz)	SRF (MHz) Min.	DC Resistance (Ω) Max.	Rated Current (mA) Max.
WIC-453232-1R0	1.00	10	7.96	180	0.11	1050
WIC-453232-1R2	1.20	10	7.96	160	0.12	1000
WIC-453232-1R5	1.50	10	7.96	130	0.15	950
WIC-453232-1R8	1.80	10	7.96	100	0.16	900
WIC-453232-2R2	2.20	10	7.96	80.0	0.18	850
WIC-453232-2R7	2.70	10	7.96	60.0	0.20	800
WIC-453232-3R3	3.30	10	7.96	45.0	0.22	750
WIC-453232-3R9	3.90	10	7.96	40.0	0.24	700
WIC-453232-4R7	4.70	10	7.96	35.0	0.27	650
WIC-453232-5R6	5.60	10	7.96	30.0	0.30	650
WIC-453232-6R8	6.80	10	7.96	28.0	0.35	600
WIC-453232-8R2	8.20	10	7.96	25.0	0.40	600
WIC-453232-100	10.00	10	2.52	22.0	0.50	550
WIC-453232-120	12.00	10	2.52	21.0	0.60	500
WIC-453232-150	15.00	10	2.52	20.0	0.70	450
WIC-453232-180	18.00	10	2.52	19.0	0.80	400
WIC-453232-220	22.00	10	2.52	18.0	0.90	370
WIC-453232-270	27.00	10	2.52	16.0	1.20	330
WIC-453232-330	33.00	10	2.52	14.0	1.40	300
WIC-453232-390	39.00	10	2.52	12.0	1.60	280
WIC-453232-470	47.00	10	2.52	11.5	1.90	260
WIC-453232-560	56.00	10	2.52	11.0	2.20	240
WIC-453232-680	68.00	10	2.52	10.0	2.60	220
WIC-453232-820	82.00	10	2.52	9.0	3.50	200
WIC-453232-101	100.00	20	0.796	8.0	4.00	180
WIC-453232-121	120.00	20	0.796	7.5	4.50	160
WIC-453232-151	150.00	20	0.796	7.0	6.50	140
WIC-453232-181	180.00	20	0.796	6.5	7.50	120
WIC-453232-221	220.00	20	0.796	5.5	9.00	120
WIC-453232-271	270.00	20	0.76	5.0	11.0	100
WIC-453232-331	330.00	20	0.796	4.0	13.0	90
WIC-453232-391	390.00	30	0.796	3.0	13.5	85
WIC-453232-471	470.00	30	0.796	3.0	15.0	75

(J=5%, K=10%, M=20%)



Part Number	Inductance (μ H)	Q Min.	L, Q Test Frequency (MHz)	SRF (MHz) Min.	DC Resistance (Ω) Max.	Rated Current (mA) Max.
WIC-453232-561	560.00	30	0.796	3.0	17.0	70
WIC-453232-681	680.00	30	0.796	2.5	22.8	65

(J=5%, K=10%, M=20%)



STANDARD PACKAGING (WOUND CHIP INDUCTORS)

- TAPE DIMENSION

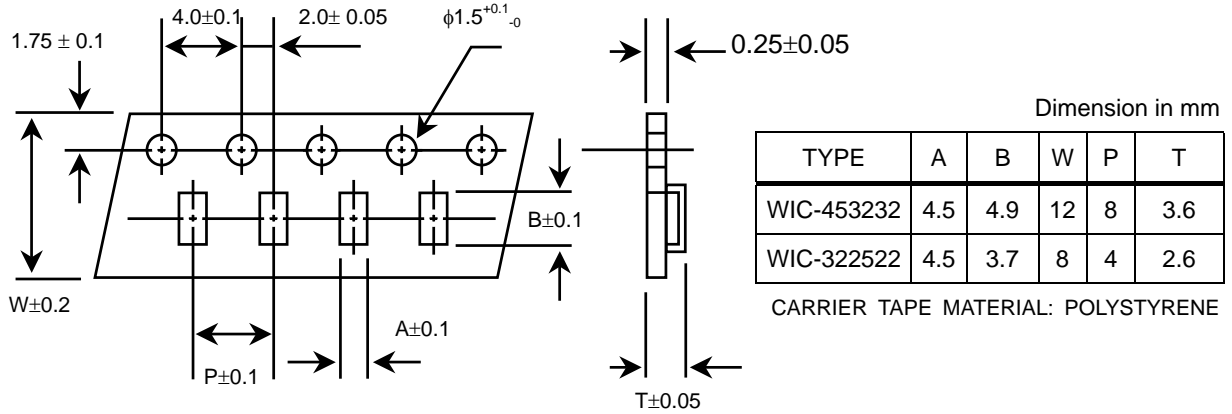

- REEL DIMENSION

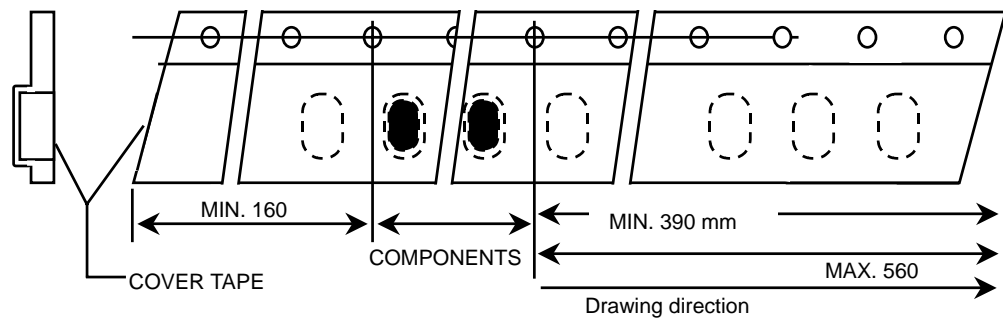
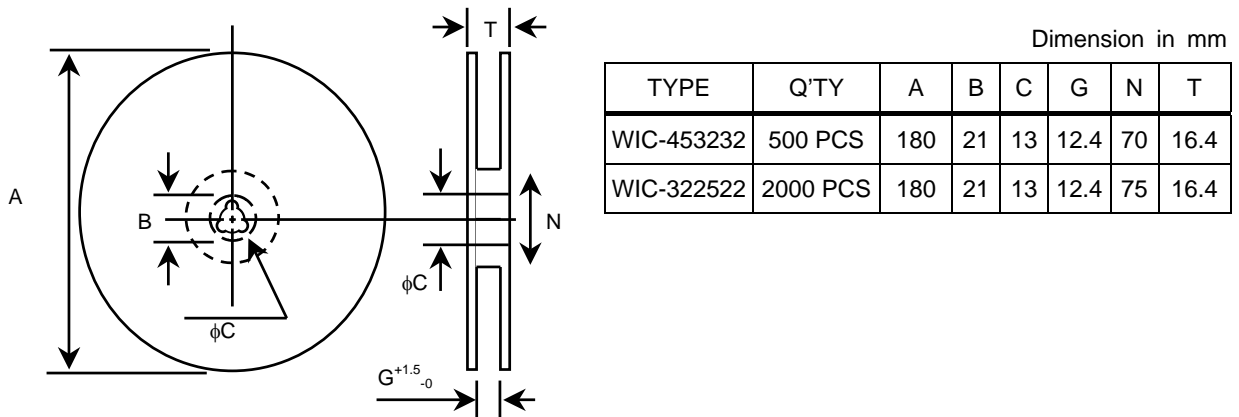



WHI TYPE

STRUCTURE AND APPEARANCE

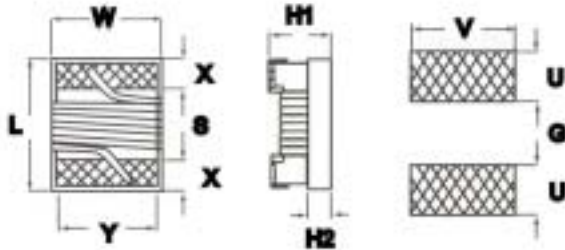

DIMENSION

DIM: mm

TYPE	L MAX	W MAX	H1 MAX	H2 REF	S	X	Y	G	U	V
WHI 0603	1.80	1.12	1.02	0.38	0.86	0.33	0.76	0.64	0.64	1.02
WHI 0805	2.29	1.73	1.52	0.51	1.02	0.51	1.27	0.76	1.02	1.78
WHI 1008	2.92	2.79	2.29	0.51	1.52	0.51	2.03	1.27	1.02	2.54

**Electrical specifications (WHI 0603)**

Parts No.	Inductance (nH)	Tolerance%	Q Min	SRF Min (MHz)	DCR Max (Ω)	IDC Max (mA)	900MHz		1.7GHz	
							L Typ	Q Typ	L Typ	Q Typ
WHI 0603-1N6	1.6@250MHz	10 / 5	24	12500	0.030	700	1.67	49	1.65	63
WHI 0603-1N8	1.8@250MHz	10 / 5	16	12500	0.045	700	1.63	35	1.66	50
WHI 0603-3N6	3.6@250MHz	10 / 5	22	5900	0.063	700	3.72	53	3.71	65
WHI 0603-3N9	3.9@250MHz	10 / 5	22	6900	0.080	700	3.95	49	3.96	67
WHI 0603-4N3	4.3@250MHz	10 / 5	22	5900	0.063	700	4.32	50	4.33	70
WHI 0603-4N7	4.7@250MHz	10 / 5	20	5800	0.116	700	4.72	47	4.75	57
WHI 0603-5N1	5.4@250MHz	10 / 5	20	5700	0.140	700	4.93	47	4.95	56
WHI 0603-6N8	6.8@250MHz	10 / 5	27	5800	0.110	700	6.75	60	7.1	81
WHI 0603-7N5	7.5@250MHz	10 / 5	28	4800	0.106	700	7.7	60	7.82	65
WHI 0603-8N7	8.7@250MHz	5 / 2	28	4600	0.109	700	8.86	62	9.32	58
WHI 0603-9N5	9.5@250MHz	5 / 2	28	5400	0.135	700	9.7	59	9.92	61
WHI 0603-10N	10@250MHz	5 / 2	31	4800	0.130	700	10	66	10.6	83
WHI 0603-11N	11@250MHz	5 / 2	33	4000	0.086	700	11	53	11.5	56
WHI 0603-12N	12@250MHz	5 / 2	35	4000	0.130	700	12.3	72	13.5	83
WHI 0603-15N	15@250MHz	5 / 2	35	4000	0.170	700	15.4	64	16.8	89
WHI 0603-16N	16@250MHz	5 / 2	34	3300	0.104	700	16.2	55	17.3	52
WHI 0603-18N	18@250MHz	5 / 2	35	3100	0.170	700	18.7	70	21.4	69
WHI 0603-22N	22@250MHz	5 / 2	38	3000	0.190	700	22.8	73	26.1	71
WHI 0603-24N	24@250MHz	5 / 2	37	2650	0.135	700	24.5	45	28.7	39
WHI 0603-27N	27@250MHz	5 / 2	40	2800	0.220	600	29.2	74	34.6	65
WHI 0603-30N	30@250MHz	5 / 2	37	2250	0.144	600	31.4	47	39.9	28
WHI 0603-33N	33@250MHz	5 / 2	40	2300	0.220	600	36	67	49.5	42
WHI 0603-36N	36@250MHz	5 / 2	38	2080	0.250	600	39.4	47	52.7	24
WHI 0603-39N	39@250MHz	5 / 2	40	2200	0.250	600	42.7	60	60.2	40
WHI 0603-43N	43@250MHz	5 / 2	39	2000	0.280	600	47	44	64.9	21
WHI 0603-47N	47@200MHz	5 / 2	38	2000	0.280	600	52.5	62	77.2	35
WHI 0603-56N	56@200MHz	5 / 2	38	1900	0.310	600	62.5	56	97	26
WHI 0603-68N	68@200MHz	5 / 2	37	1700	0.340	600	80.5	54	168	21
WHI 0603-72N	72@150MHz	5 / 2	34	1700	0.490	400	82	53	135	20
WHI 0603-82N	82@150MHz	5 / 2	34	1700	0.540	400	96.2	54	177	21
WHI 0603-R10	100@150MHz	5 / 2	34	1400	0.580	400	124	49	-	-
WHI 0603-R11	110@150MHz	5 / 2	32	1350	0.610	300	138	43	-	-
WHI 0603-R12	120@150MHz	5 / 2	32	1300	0.650	300	166	39	-	-
WHI 0603-R15	150@150MHz	5 / 2	28	990	0.920	280	250	25	-	-
WHI 0603-R18	180@100MHz	5 / 2	25	990	1.250	240	305	22	-	-
WHI 0603-R22	220@100MHz	5 / 2	25	900	2.100	200	480	8	-	-
WHI 0603-R27	270@100MHz	5 / 2	24	900	2.300	170	980	4	-	-

- 1.Tolerance:J=5%, K=10%, M=20%
- 2.IDC For 15 °C rise.
- 3.Operating temperature range -40 °C to + 125 °C.
- 4.Electrical specifications at 25 °C.

**Electrical specifications (WHI 0805)**

Parts No.	Inductance (nH)	Tolerance %	Q Min	SRF (MHz) Min	DCR(Ω) Max	IDC (mA) Max
WHI 0805-2N2	2.2@250MHz	20 / 10	50@1500MHz	6000	0.05	600
WHI 0805-3N3	3.3@250MHz	20 / 10	50@1500MHz	6000	0.08	600
WHI 0805-6N8	6.8@250MHz	20 / 10	50@1000MHz	5500	0.11	600
WHI 0805-8N2	8.2@250MHz	20 / 10	50@500MHz	4700	0.12	600
WHI 0805-12N	12@250MHz	20 / 10	50@500MHz	4000	0.15	600
WHI 0805-15N	15@250MHz	20 / 10	50@500MHz	3400	0.17	600
WHI 0805-18N	18@250MHz	20 / 10	50@500MHz	3300	0.20	600
WHI 0805-22N	22@250MHz	20 / 10	55@500MHz	2500	0.22	500
WHI 0805-27N	27@250MHz	20 / 10	55@500MHz	2500	0.25	500
WHI 0805-33N	33@250MHz	20 / 10	60@500MHz	2050	0.27	500
WHI 0805-39N	39@250MHz	10 / 5	60@500MHz	2000	0.29	500
WHI 0805-47N	47@200MHz	10 / 5	60@500MHz	1650	0.31	500
WHI 0805-56N	56@200MHz	10 / 5	60@500MHz	1550	0.34	500
WHI 0805-68N	68@200MHz	10 / 5	60@500MHz	1450	0.38	500
WHI 0805-82N	82@150MHz	10 / 5	65@500MHz	1300	0.42	400
WHI 0805-R10	100@150MHz	10 / 5	65@500MHz	1200	0.46	400
WHI 0805-R12	120@150MHz	10 / 5	50@250MHz	1100	0.51	400
WHI 0805-R15	150@100MHz	10 / 5	50@250MHz	920	0.56	400
WHI 0805-R18	180@100MHz	10 / 5	50@250MHz	870	0.64	400
WHI 0805-R22	220@100MHz	10 / 5	50@250MHz	850	0.70	400
WHI 0805-R27	270@100MHz	10 / 5	40@250MHz	950	1.00	280
WHI 0805-R33	330@100MHz	10 / 5	40@250MHz	890	1.20	260
WHI 0805-R39	390@100MHz	10 / 5	40@250MHz	830	1.50	200
WHI 0805-R47	470@100MHz	10 / 5	40@100MHz	750	2.50	170
WHI 0805-R56	560@100MHz	10 / 5	40@100MHz	700	3.50	170
WHI 0805-R68	680@50MHz	10 / 5	30@50MHz	650	4.00	170

1. Tolerance: J=5%, K=10%, M=20%
2. IDC For 15 °C rise.
3. Operating temperature range -40 °C to + 125 °C.
4. Electrical specifications at 25 °C.

**Electrical specifications (WHI 1008)**

Parts No.	Inductance (nH)	Tolerance %	Q Min	SRF (MHz) Min	DCR(Ω) Max	IDC (mA) Max
WHI 1008-10N	10@50MHz	20 / 10	50@500MHz	4100	0.08	1000
WHI 1008-12N	12@50MHz	20 / 10	50@500MHz	3300	0.09	1000
WHI 1008-15N	15@50MHz	20 / 10	50@500MHz	2500	0.10	1000
WHI 1008-18N	18@50MHz	20 / 10	50@350MHz	2500	0.11	1000
WHI 1008-22N	22@50MHz	20 / 10	55@350MHz	2400	0.12	1000
WHI 1008-27N	27@50MHz	20 / 10	55@350MHz	1600	0.13	1000
WHI 1008-33N	33@50MHz	20 / 10	60@350MHz	1600	0.14	1000
WHI 1008-39N	39@50MHz	20 / 10	60@350MHz	1500	0.15	1000
WHI 1008-47N	47@50MHz	20 / 10	65@350MHz	1500	0.16	1000
WHI 1008-56N	56@50MHz	10 / 5	65@350MHz	1300	0.18	1000
WHI 1008-68N	68@50MHz	10 / 5	65@350MHz	1300	0.20	1000
WHI 1008-82N	82@50MHz	10 / 5	60@350MHz	1000	0.22	1000
WHI 1008-R10	100@25MHz	10 / 5	60@350MHz	1000	0.56	650
WHI 1008-R12	120@25MHz	10 / 5	60@350MHz	950	0.63	650
WHI 1008-R15	150@25MHz	10 / 5	45@100MHz	850	0.70	620
WHI 1008-R18	180@25MHz	10 / 5	45@100MHz	750	0.77	580
WHI 1008-R22	220@25MHz	10 / 5	45@100MHz	700	0.84	500
WHI 1008-R27	270@25MHz	10 / 5	45@100MHz	600	0.91	500
WHI 1008-R33	330@25MHz	10 / 5	45@100MHz	570	1.05	450
WHI 1008-R39	390@25MHz	10 / 5	45@100MHz	500	1.12	450
WHI 1008-R47	470@25MHz	10 / 5	45@100MHz	450	1.19	450
WHI 1008-R56	560@25MHz	10 / 5	45@100MHz	415	1.33	400
WHI 1008-R62	620@25MHz	10 / 5	45@100MHz	375	1.40	300
WHI 1008-R68	680@25MHz	10 / 5	45@100MHz	375	1.47	350
WHI 1008-R75	750@25MHz	10 / 5	45@100MHz	360	1.54	360
WHI 1008-R82	820@25MHz	10 / 5	45@100MHz	350	1.61	350
WHI 1008-R91	910@25MHz	10 / 5	45@100MHz	320	1.68	380
WHI 1008-1R0	1000@25MHz	10 / 5	35@50MHz	290	1.75	370
WHI 1008-1R2	1200@7.9MHz	10 / 5	37@50MHz	250	2.00	350
WHI 1008-1R5	1500@7.9MHz	10 / 5	28@50MHz	200	2.30	300
WHI 1008-1R8	1800@7.9MHz	10 / 5	28@50MHz	160	2.60	300
WHI 1008-2R2	2200@7.9MHz	10 / 5	28@50MHz	160	2.80	300
WHI 1008-2R7	2700@7.9MHz	10 / 5	22@25MHz	140	3.20	270
WHI 1008-3R3	3300@7.9MHz	10 / 5	22@25MHz	110	3.40	270
WHI 1008-3R9	3900@7.9MHz	10 / 5	22@25MHz	100	3.60	250
WHI 1008-4R7	4700@7.9MHz	10 / 5	22@25MHz	90	4.00	250

- 1.Tolerance:J=5%, K=10%, M=20%
- 2.IDC For 15 °C rise.
- 3.Operating temperature range -40 °C to + 125 °C.
- 4.Electrical specifications at 25 °C.



STANDARD PACKAGING

● TAPE DIMENSIONS

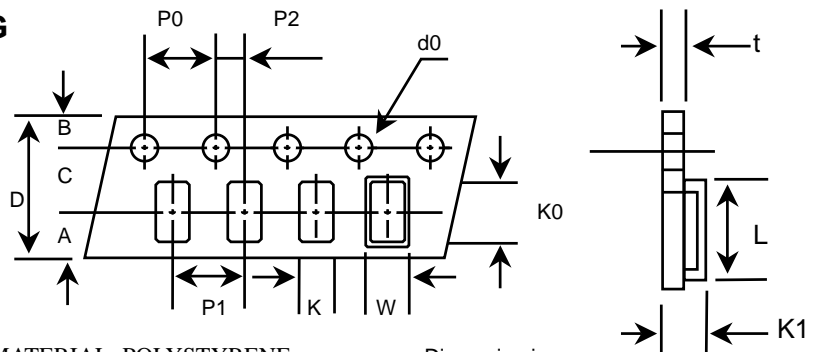

CARRIER TAPE MATERIAL: POLYSTYRENE

Dimension in mm

SYM	WHI 0805	WHI 1008
A	2.75	2.75
B	1.75 ± 0.10	1.75 ± 0.10
C	3.50 ± 0.05	3.50 ± 0.05
D	8.00 ± 0.20	8.00 ± 0.20
K	2.20 ± 0.10	3.10 ± 0.10
K0	2.70 ± 0.10	3.20 ± 0.10
K1	1.40 ± 0.10	2.24 ± 0.05
L	2.85	3.50
W	2.35	3.30
P0	4.00 ± 0.10	4.00 ± 0.10
P1	4.00 ± 0.10	4.00 ± 0.10
P2	2.00 ± 0.05	2.00 ± 0.05
d0	1.50 ^{+0.10} _{-0.00}	1.50 ^{+0.10} _{-0.00}
t	0.20 ± 0.05	0.30 ± 0.05

● REEL DIMENSIONS

Dimension in mm

TYPE	WHI 0805	WHI 1008
Q'TY	2000 PCS	2000 PCS
A	180/330	180/330
B	62.0 ± 1.50	62.0 ± 1.50
C	12.75 ± 0.15	12.75 ± 0.15
W	10.0	10.0

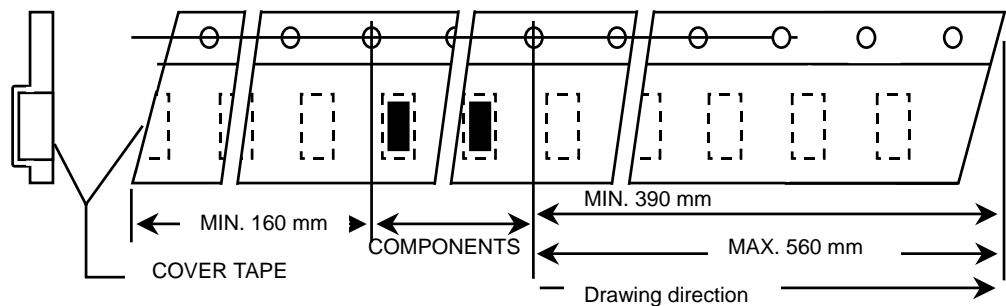
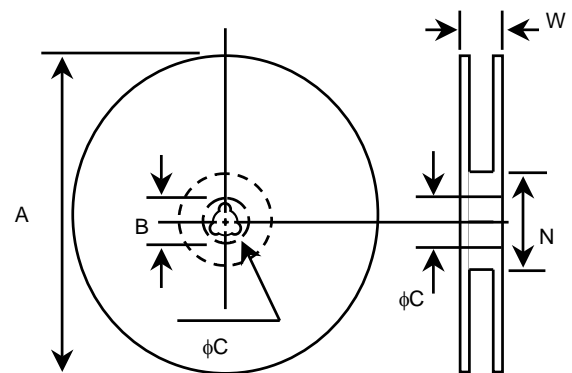

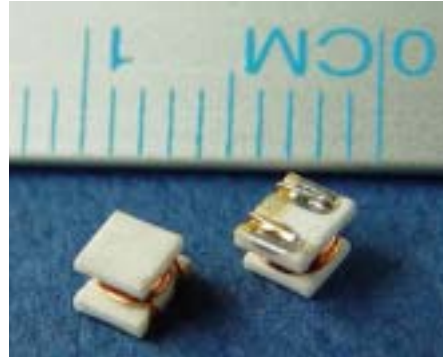
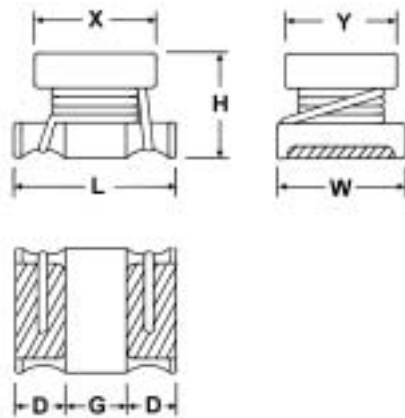
**HPA TYPE****STRUCTURE AND APPEARANCE****DIMENSION**

DIM: mm

TYPE	L	W	H	X	Y	G	D
HPA21A	20. ± 0.2	1.5 ± 0.2	1.7 ± 0.1	1.5 ± 0.2	1.5 ± 0.2	0.5 min	0.5 min
HPA1A	3.2 ± 0.3	2.5 ± 0.2	2.0 ± 0.2	2.5 ± 0.2	2.5 ± 0.2	0.7 min	0.7 min

FEATURES

HPA1A/HPA21A series

- The HPA1A/HPA21A series consists of air-core chip coil using a sub-miniature alumina core as a bobbin.
- The high Q value at high frequencies and self-resonant frequencies.
- This coil perfect for use in the high frequency circuits of communications equipment.

HPA1A

- The small dimensions (3.2×1.6×1.8 mm) allow parallel mounting on 2.5mm centers.
- The maximum current rating up to 970 mA for 0.12 μH.

HPA21A1

- Inductance tolerance ±0.5 nH(8.2 nH max.), ±5%(10 nH to 220 nH) and ±10%(270 nH to 470 nH) are realized.
- The sub miniature dimensions (2.0×1.2 mm) allow high-density mounting.

HPA21A2

- Tight inductance tolerance of ±2% is available.

HPA21A3

- HPA21A3 using thick wire has higher Q value than existing HPA21A1 series.
- Low DC resistance design enables to handle higher current.



Electrical specifications (HPA21A1)

Part No.	Inductance			Q			DC Resistance (Ω)	Self resonant Freq. (MHz) min.	Allowable Current mA	Operating Temp. Range		
	Value (nH)	Tolerance (%)	Test Freq.	Peak Value (Typ.)	Min Value	Test Freq.						
3N3	3.3	±0.5 nH	100 MHz	70	10	250 MHz	0.05	6000	910	-25 °C to +85 °C		
6N8	6.8	±0.5 nH (±10)			20		30	0.11	5400		680	
8N2	8.2							0.12	3900		630	
10N	10	±5 (±10)		80	40	200 MHz	0.03	3300	1320			
12N	12			65			0.11	3200	680			
15N	15			70			30	100 MHz	0.12		2700	630
18N	18								0.10		2600	690
22N	22			65			40	200 MHz	0.09		2100	720
27N	27								0.17		2300	540
33N	33			80			30	150 MHz	0.15		1900	570
39N	39								0.09		1700	730
47N	47			70			40	200 MHz	0.23		1600	450
56N	56								0.26		1500	430
58N	68	65		30	100 MHz	0.23	1200	460				
82N	82					0.42	1100	320				
R10	100	70		40	150 MHz	0.38	900	350				
R12	120					0.40	750	320				
R15	150	50		35	100 MHz	0.47	350	390				
R18	180					0.71	700	250				
R22	220	70		30	25.2M HZ	0.70	500	240				
R27	270		2.00			550	190					
R33	330	±10	10 MHz	15	25.2M HZ	2.20	500	180				
R39	390					2.50	400	170				
R47	470					2.80	350	160				

Electrical specifications (HPA21A2)

Part No.	Inductance			Q			DC Resistance (Ω)	Self resonant Freq. (MHz) min.	Allowable Current mA	Operating Temp. Range
	Value (nH)	Tolerance (%)	Test Freq.	Peak Value (Typ.)	Min Value	Test Freq.				
33N	33	±2	100 MHz	65	40	250 MHz	0.15	1900	570	-25 °C to +85 °C
39N	39						80	40	200 MHz	
47N	47			65	30	150 MHz				
56N	56						70	40	200 MHz	
58N	68			65	30	100 MHz				
82N	82						60	35	150 MHz	
R10	100			55	40	100 MHz				
R12	120						0.40	750	320	
R15	150			55	30	25.2M HZ	0.47	350	390	
R18	180						0.71	700	250	
R22	220			70	30	25.2M HZ	0.70	500	240	

**Electrical specifications (HPA21A3)**

Part No.	Inductance			Q				DC Resistance (Ω)	Self Resonant Freq. (MHz) min.	Allowable Current (mA)	Operating Temp. Range	
	Value (nH)	Tolerance (%)	Test Freq.	Min. Value	Test Freq.	800 MHz (Typ.)	1.5 GHz (Typ.)					
2N7	3	± 0.5 nH	100 MHz	20	250 MHz	85	120	0.02	6000	1900	-25 °C to +85 °C	
3N1	3						110			1800		
3N3	3.3						115			1700		
5N6	5.6						100			1500		
6N8	6.8						95			1400		
8N6	8.6	± 5	35	250 MHz	85	100	0.03	3900	1300			
10N	10								85	1320		
12N	12	± 10	100 MHz	40	250 MHz	100	90	0.04	3200	1100		
15N	15									3100		1000
18N	18.8									2600		1000
21N	21									2200		950
27N	27									1800	900.0	

Electrical specifications (HPA1A)

Part No.	Inductance			Q			DC Resistance (Ω)	Self Resonant Freq. (MHz) min.	Allowable Current (mA)	Operating Temp. Range
	Value (nH)	Tolerance (%)	Test Freq.	Peak Value (Typ.)	Min Value	Test Freq.				
8N8	8.8	± 10 (± 5)	100 MHz	100	60	436 MHz	0.39 \pm 40 %	1000	750	-25 °C to +85 °C
15N	14.7						0.43 \pm 40 %		680	
17N	17						0.45 \pm 40 %		650	
23N	23						0.83 \pm 40 %		590	
27N	27						0.61 \pm 40 %		560	
33N	33			0.67 \pm 40 %	530					
39N	39			0.73 \pm 40 %	490					
47N	47			90	0.49 \pm 30 %	380				
56N	56			80	0.9 \pm 30 %	330				
64N	64			70	1.0 \pm 30 %	290				
84N	84			1.6 \pm 30 %	240					
R10	100			0.7 \pm 30 %	900	230				